

**INTERNATIONAL ENERGY AGENCY
IEA DISTRICT HEATING AND COOLING**

**Programme of Research, Development and Demonstration on
District Heating and Cooling**

District Heating and Cooling Connection Handbook

Bard Skagestad¹, Peter Mildenstein²

¹Kattner/FVB District Energy Inc. Canada

²Sheffield Heat and Power Group, UK

1 Preface

Introduction

The International Energy Agency (IEA) was established in 1974 in order to strengthen the co-operation between member countries. As an element of the International Energy Programme, the participating countries undertake co-operative actions in energy research, development and demonstration.

District Heating offers excellent opportunities for achieving the twin goals of saving energy and reducing environmental pollution. It is an extremely flexible technology which can make use of any fuel including the utilisation of waste energy, renewables and, most significantly, the application of combined heat and power (CHP). It is by means of these integrated solutions that very substantial progress towards environmental targets, such as those emerging from the Kyoto commitment, can be made.

For more information about this Implementing Agreement please check our Internet site www.iea-dhc.org/

Annex VI

In May 1999 Annex VI started.

The countries that participated were:

Canada, Denmark, Finland, Germany, Korea, The Netherlands, Norway, Sweden, United Kingdom, United States of America.

The following projects were carried out in Annex VI:

Title project	ISBN	Registration number
Simple Models for Operational Optimisation	90 5748 021 2	S1
Optimisation of a DH System by Maximising Building System Temperatures Differences	90 5748 022 0	S2
District Heating Network Operation	90 5748 023 9	S3
Pipe Laying in Combination with Horizontal Drilling Methods	90 5748 024 7	S4
Optimisation of Cool Thermal Storage and Distribution	90 5748 025 5	S5
District Heating and Cooling Building Handbook	90 5748 026 3	S6
Optimised District Heating Systems Using Remote Heat Meter Communication and Control	90 5748 027 1	S7
Absorption Refrigeration with Thermal (ice) Storage	90 5748 028 X	S8
Promotion and Recognition of DHC/CHP benefits in Greenhouse Gas Policy and Trading Programs	90-5748-029-8	S9

Benefits of Membership

Membership of this implementing agreement fosters sharing of knowledge and current best practice from many countries including those where:

- DHC is already a mature industry
- DHC is well established but refurbishment is a key issue
- DHC is not well established.

Membership proves invaluable in enhancing the quality of support given under national programmes. The final materials from the research are tangible examples, but other benefits include the cross-fertilisation of ideas which has resulted not only in shared knowledge but also opportunities for further collaboration.

Participant countries benefit through the active participation in the programme of their own consultants and research organizations. Each of the projects is supported by a team of Experts, one from each participant country. The sharing of knowledge is a two-way process, and there are known examples of the expert him/herself learning about new techniques and applying them in their own organization.

Information

General information about the IEA Programme District Heating and Cooling, including the integration of CHP can be obtained from:

IEA Secretariat
Mr. Hans Nilsson
9 Rue de la Federation
F-75139 Paris, Cedex 15
FRANCE
Telephone: +33-1-405 767 21
Fax: +33-1-405 767 49
E-mail: hans.nilsson@iea.org
or
The Operating Agent
NOVEM
Ms. Marijke Wobben
P.O. Box 17
NL-6130 AA SITTARD
The Netherlands
Telephone: +31-46-4202322
Fax: +31-46-4528260
E-mail: m.wobben@novem.nl

Acknowledgements

The work carried out for this project has been monitored by an Experts Group and the authors would like to thank the members for their valuable guidance and advice. The members of the Experts Group were:

N. Andersen (Denmark)
A. Jones (UK)
K. D. Koo (South Korea)
G. Nilsson (Sweden)
P.G. Ramsek (The Netherlands)
F. Schmidt (Germany)
J. Stang (Norway)
M. Tiitinen (Finland)
R. Volla (Norway)

2 Summary

This report is intended to assist engineers and consultants in designing and implementing conversions of building HVAC systems to accept chilled and hot water from district energy systems. Building types that are addressed include residential, commercial, institutional and industrial. The practical guidelines provided are based on extensive conversion and operating experience. As well as highlighting the most cost effective approach to conversions, the guidelines ensure that technically sound systems are built.

The report looks at the fundamentals and principles of both district heating and cooling including energy sources, distribution and customer interface. Design considerations of these three main components of district energy are described, as well as the benefits that district energy can bring to the building owners, the municipality and the public.

Critical points in designing the interface between the building energy system and the district energy system (energy transfer station) are outlined and are intended for use in the design of new building systems as well as for conversions of existing buildings. Detailed schematics of energy transfer stations are shown illustrating all components, including control equipment, heat exchangers and energy meter. Energy transfer station performance is detailed with graphs showing the impact of various parameters within a district energy system. The report also highlights the considerations of design and operation of the secondary system or the system that uses the energy from the district energy system.

The report also breaks down, step by step, the procedure to convert a building to accept district energy. These include building survey and schematic design, energy consumption, compatibility, costs, system optimization, construction schedule, testing and commissioning. The suitability of a given system to be converted is also discussed.

The importance of a correct determination of the heating and cooling demand of a building is stressed, because a proper sizing of the heat exchanger in the energy transfer station affects the operation of the system in a major way. Several methods to determine this load demand value are described. The optimization of the heat exchanger is also very important because it forms a large part of the capital cost of the energy transfer station.

Some case histories of buildings connected to a district cooling system are described.

Table of Contents

1 PREFACE	ii
2 SUMMARY	iv
PART I: COOLING SECTION	10
3 INTRODUCTION	12
4 FUNDAMENTALS OF DISTRICT COOLING	13
Principles of District Cooling	13
4.1.1 Cooling Source	13
4.1.2 Distribution	14
4.1.3 Customer Interface or Energy Transfer Station	15
Design Considerations	16
4.1.4 General Considerations	16
4.1.5 Cooling Sources	17
4.1.6 Distribution	20
4.1.7 Energy Transfer Stations	21
Benefits of District Cooling Systems	22
4.1.8 Property / Building Owners	22
4.1.9 Municipalities	22
4.1.10 Society	22
5 DESIGNING FOR INTERFACE WITH DISTRICT COOLING	23
Introduction	23
Energy Transfer Station – Indirect Connection	23
5.1.1 Heat Exchangers	23
5.1.2 Heat Exchanger Performance	25
5.1.3 Controls	26
5.1.4 Energy Meters	28
5.1.5 Other Equipment	30
5.1.6 Location of Energy Transfer Station	31
Energy Transfer Station - Direct Connection	31
5.1.7 ETS Connection Criteria	32
Secondary Systems	33
5.1.8 General Considerations	33
5.1.9 Building Secondary/Tertiary System Pumps	34
5.1.10 Air Handling Units Coils and Other Terminal Equipment	35
5.1.11 Water Treatment	36
5.1.12 Expansion System	36
6 BUILDING CONVERSION	37
Introduction	37
Cooling Systems Types and Conversion Suitability	37
Procedure for Building Conversion	38
6.1.2 Building Survey and Schematic Design	38
6.1.3 Building Peak Cooling Load and Energy Requirements	39
6.1.4 Component Compatibility	39
6.1.5 Conversion Concept and Costs	40
6.1.6 System Optimization and Detailed Design	40
6.1.7 Construction Schedule	40
6.1.8 Testing and Commissioning	40
Low ΔT Discussion	40
6.1.9 General	40
6.1.10 Low ΔT Causes and Mitigation	41
Chilled Water Systems	42
6.1.11 Chilled Water Distribution	42
6.1.12 Radiant Panel or Induction Systems	43
6.1.13 Induction Systems	43
6.1.14 Air Handling Systems	43
6.1.15 Fan Coil Units	43

Electrical Systems	43
6.1.16 Rooftop Units	43
6.1.17 Heat Pumps	44
6.1.18 Packaged A/C Units	44
Other Considerations	44
6.1.19 Recapturing of Space	44
6.1.20 Staffing and Management	44
7 APPENDIX: CASE HISTORIES – CONVERSION TO DISTRICT COOLING	45
Case History 1 - BNC AMERICANA Building, Houston, Texas, USA	45
7.1.1 Existing Cooling System	45
7.1.2 Conversion.....	45
7.1.3 Recommended Cooling Equipment	46
7.1.4 Conversion Costs – (2001\$).....	46
7.1.5 Results.....	47
Case History 2 – Kv. Grävlingen (an office and retail building), Stockholm, Sweden	48
7.1.6 Summary	48
7.1.7 General	48
7.1.8 Building Cooling System Description Prior to Conversion	48
7.1.9 Building Cooling System Description After Conversion.....	49
7.1.10 Further Changes To The Building	50
PART II: HEATING SECTION	51
8 INTRODUCTION	52
9 EXISTING INSTALLATIONS	53
Introduction	53
Design Principles – Hydronic Heating	53
9.1.1 Pressure Regimes.....	53
9.1.2 Temperature Regimes	53
System Suitability	54
9.1.3 Two-pipe Radiator Systems.....	54
9.1.4 Single-pipe Radiator Systems.....	54
9.1.5 Convector and Air Handling Unit (AHU) Heating	54
9.1.6 Radiant Panel Heating.....	54
9.1.7 Under Floor and Embedded Panel Heating	54
9.1.8 Electric Heating Systems	54
9.1.9 Steam Systems.....	55
9.1.10 Localized Gas-fired Heaters.....	55
9.1.11 Domestic Hot Water Heating Systems	55
10 FUNDAMENTALS OF DISTRICT HEATING	56
Heat Sources	56
Distribution System	57
Customer Interface	62
Benefits to the User	64
11 INTERFACE DESIGN	66
Introduction	66
Design Considerations	66
11.1.1 Pre-Design Survey	66
11.1.2 Secondary Design Temperatures	67
11.1.3 Domestic Hot Water - Design Temperatures.....	68
Heat Exchanger Substation Design	69
11.1.4 General	69
11.1.5 Heat Exchanger	69
11.1.6 Heat Exchanger Specification.....	71
11.1.7 Controls	72
11.1.8 Ancillary Equipment	73
11.1.9 Heat Exchanger Substation Location.....	74
Connection Methods	74
11.1.10 Indirect Connection Method	74
11.1.11 Direct Connection Method.....	76
Secondary Heating Systems	79

11.1.12 General Considerations.....	79
11.1.13 Distribution.....	79
11.1.14 Heating & Ventilating Equipment.....	80
Domestic Hot Water	80
11.1.15 DHW Heat Exchanger	80
11.1.16 Temperature Control	80
12 BUILDING CONVERSION	81
Introduction.....	81
Conversion Procedure	81
13 RELATED REFERENCES	84
14 GLOSSARY	85

List of Figures

Part I Figure 4.1: Elements of a district cooling system.....	13
Part I Figure 4.2: Distribution system pressure differentials for a cooling system for winter and summer conditions	14
Part I Figure 4.3: Typical temperature reset of the primary water in a district cooling system	15
Part I Figure 4.4: Typical ETS for indirect connection.....	15
Part I Figure 4.5: Basic building cooling system schematic	16
Part I Figure 4.6: Typical screw compressor (courtesy of Mycom).....	17
Part I Figure 4.7: Temperature differentials versus pipe diameter.....	20
Part I Figure 4.8: Typical direct buried piping installation	21
Part I Figure 5.1: Picture of typical PHE (courtesy of Alfa Laval).....	24
Part I Figure 5.2: Principal connection methods for uniform flow	24
Part I Figure 5.3: PHE performance with variable primary flow and constant secondary flow.....	25
Part I Figure 5.4: PHE performance with variable primary and secondary flows	26
Part I Figure 5.5: Heat exchanger and associated components.....	27
Part I Figure 5.6: ETS panel photo (courtesy of Thermal Automation Canada).....	28
Part I Figure 5.7: Typical installation of the energy meter	30
Part I Figure 5.8: Magnetic inductive flow meter (courtesy of Endress & Hauser).....	30
Part I Figure 5.9: Direct connection of building system to the district cooling system	31
Part I Figure 5.10: Cooling system with multiple building zone pumps and sub-circuits	34
Part I Figure 5.11: Pump characteristics at 50% flow rate.....	35
Part I Figure 5.12: Typical air-handling unit connection to secondary system.....	36
Part I Figure 6.1: Generic coil performance for varying supply air temperature	41
Part I Figure 6.2: AHU coil performance for variable flow and supply air temperatures.....	42
Part I Figure 7.1: Exterior view of Americana building	45
Part I Figure 7.2: ETS location before installation	45
Part I Figure 7.3: ETS after installation	46
Part I Figure 7.4: Kv. Grävlingen building ETS and secondary system flow schematic	50
Part II Figure 10.1: Network configuration with main heat source, transmission network, boiler plants/sub-stations and distribution network	56
Part II Figure 10.2: Example of a load duration curve indicating the proportion of different heat sources.....	57
Part II Figure 10.3: DH network pressure diagram.....	58
Part II Figure 10.4: Comparative pipe diameters in relation to temperature difference.....	58
Part II Figure 10.5: DH compensation curve	59
Part II Figure 10.6: Relationship between expected life of pipe and continuous operating temperature	60
Part II Figure 10.7: Diagram of Alstom pipework	61
Part II Figure 10.8: Diagram of Pipe2000 Brugg Pipework	61
Part II Figure 10.9: Directly connected installation. The main pipes are coming into the building in the foreground	63
Part II Figure 10.10: Heat exchanger substation located above a car park bay.....	64
Part II Figure 11.1: Heat exchanger for hot water supply in an office building connected directly to the DH system.....	69
Part II Figure 11.2: A complete heat exchanger substation	70
Part II Figure 11.3: Brazed plate heat exchangers	70
Part II Figure 11.4: Typical shell and spiral tube heat exchanger.....	71
Part II Figure 11.6: Schematic of a heat exchanger substation	73
Part II Figure 11.7: Schematic representation of an indirect connection	75
Part II Figure 11.8: Schematic representation of DHW pre-heating	75
Part II Figure 11.9: Schematic representation circuit mixing	76
Part II Figure 11.10: Schematic representation of a direct connection	77
Part II Figure 11.11: Schematic representation of a compensated direct connection.....	78
Part II Figure 11.12: Schematic representation of domestic hot water generation in a direct connection	78
Part II Figure 11.13: Schematic representation of domestic hot water generation in a direct connection through a heat exchanger ..	79
Part II Figure 11.14: Domestic substation	79

List of Tables

Part I Table 5.1: Common design temperature objectives	35
Part I Table 6.1: Conversion suitability of cooling system types.....	38
Part I Table 7.1: Heat exchanger selection for BNC Americana	46
Part I Table 7.2: Conversion cost estimate	47
Part I Table 7.3: Saving analysis summary.....	47
Part II Table 9.1: Examples of temperatures used for the design of central heating systems	53
Part II Table 11.1: Comparative design temperatures.....	67
Part II Table 11.3: Domestic hot water design temperatures	68
Part II Table 11.4: Permissible pressure losses through a heat exchanger.....	72
Part II Table 11.5: Design temperature objectives for secondary heating circuits.....	80

Part I: Cooling Section

*By
B. Skagestad
FVB Energy Inc.*

Acknowledgements

The author of the Cooling Section wishes to acknowledge the contribution of the following individuals:

- Charles Flynn of Reliant Energy Thermal Systems - Northwind Houston, for contributing the case history of the Americana Building in Houston, Texas.
- Jonas Andersson of FVB Fjärrvärmebyrån, for contributing the case history of the Kv. Grävlingen in Stockholm, Sweden

3 Introduction

This part of the handbook is intended to assist engineers and contractors in designing and implementing the conversion of buildings to chilled water based district cooling systems, for example, the distribution of chilled water at a temperature between 1°C and 4°C and a maximum pressure of 1.0 MPa (150 psig). These guidelines are applicable to a variety of building types, including residential, commercial, institutional and industrial.

These guidelines are focused on the types of conditions most likely to be found in North American chilled water district cooling systems, i.e., service to a variety of building sizes and types, applicable to both new and existing buildings. This handbook outlines both the indirect and direct connection between the district chilled water and building systems. The conversion procedures concentrate primarily on larger buildings with centralized chilled water systems.

The purpose of this handbook is to provide practical advice on converting buildings in the most cost-effective manner while ensuring that the system is technically sound and provides reliable and efficient cooling using a district cooling system. This report is based on extensive experience in converting building systems and operating these systems with district chilled water.

It is assumed that the user of these guidelines is an experienced heating, ventilation and air conditioning engineer or contractor, and therefore this report does not address the general aspects of building system design and installation.

These guidelines are not intended to supersede any guidelines or requirements set by the district cooling utility. In all instances, the engineer should always consult the district cooling utility. The design engineer shall be responsible for the detailed design, specification, and final selection of all equipment, systems, and components.

These guidelines follow the format of the IEA District Heating Handbook 1990.

4 Fundamentals of District Cooling

Principles of District Cooling

District cooling is a system in which chilled water is distributed in pipes from a central cooling plant to buildings for space cooling and process cooling. A district cooling system contains three major elements: the cooling source, a distribution system, and customer installations, also referred to as energy transfer stations (ETS). These elements are depicted in Figure 4.1.

District cooling systems can be subdivided into three groups based on supply temperatures:

- Conventional chilled water temperatures¹: 4°C (39°F) to 7°C (45°F)
- Ice water systems: +1°C (34°F)
- Ice slurry systems: -1°C (30°F)

This report focuses on the conventional and ice water based chilled water systems, which are generally designed for a maximum pressure of 1030 kPa (150 psig). A brief general discussion on ice slurry system technology is also included.

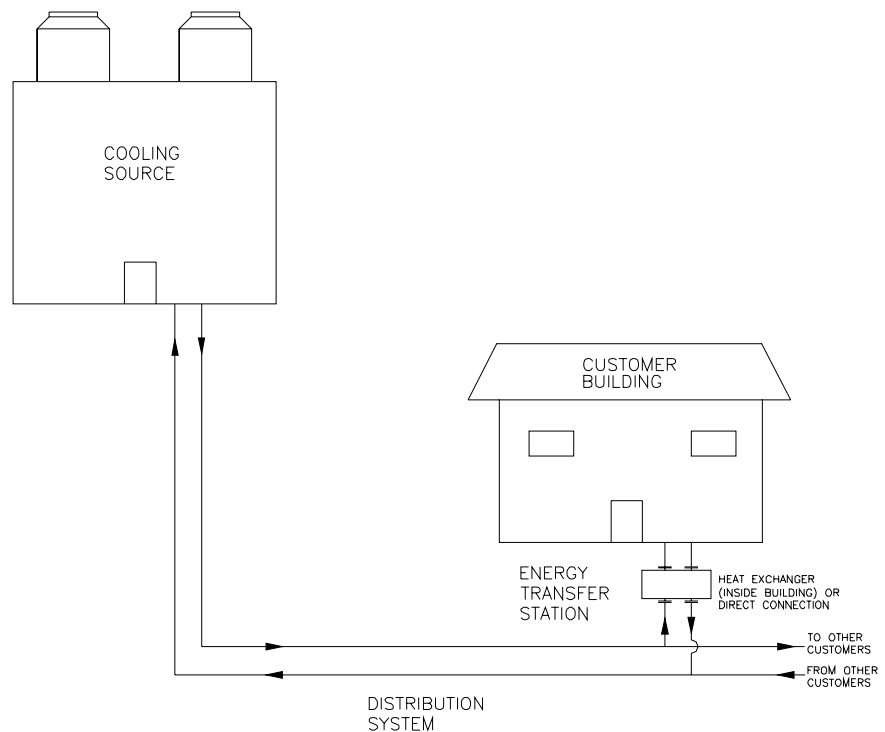

Part 1 Figure 4.1: Elements of a district cooling system

4.1.1 Cooling Source

Chilled water is typically generated at the district cooling plant by compressor driven chillers, absorption chillers or other sources like ambient cooling or “free cooling” from deep lakes, rivers, aquifers or oceans. Cooling methods are discussed in more detail in Section 4.2.2.

¹ Refers to conventional temperatures commonly used in North America. Higher temperatures can be used in some cases.

4.1.2 Distribution

District chilled water is distributed from the cooling source(s) to the customers through supply pipes and is returned after extracting heat from the building's secondary chilled water systems. Pumps distribute the chilled water by creating a pressure differential (DP) between the supply and return lines. Figure 4.2 illustrates the pressures in a simplified distribution system with a single plant configuration, using variable speed pumps, during winter (Figure 4.2-a) and summer conditions (Figure 4.2-b). The pump head (P_H) is selected to overcome the flow resistance in the supply and return lines plus the pressure differential in the customer installation or energy transfer station at the critical node of the system (P_C). For a system with a single cooling source, the critical node is normally at the end of the system. For systems with multiple plants, the system critical node typically varies depending on the operating mode and season. One or multiple control valves, sized for a large flow operating range responsive to the variations in the demand for cooling in the building, governs the amount of water that flows through each building ETS.

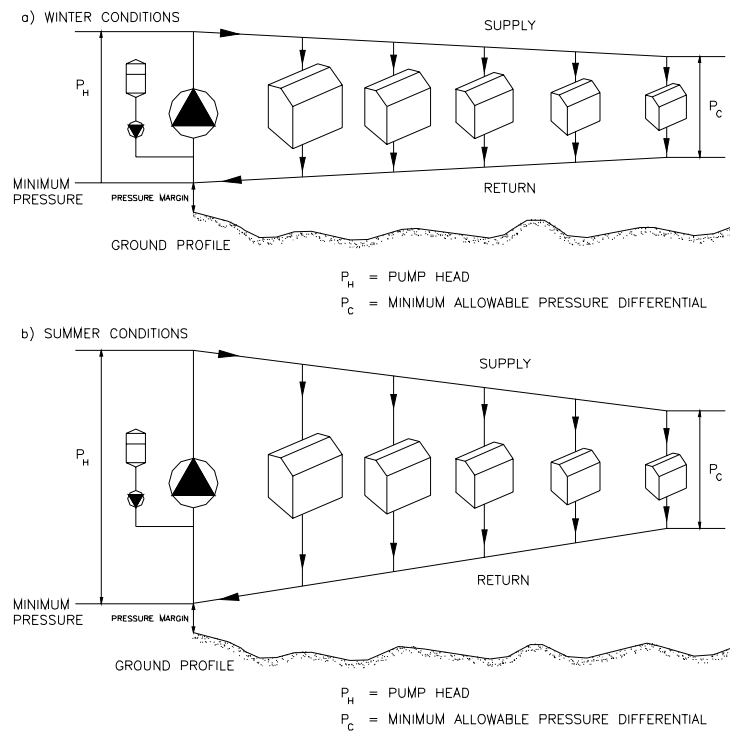

Part I Figure 4.2: Distribution system pressure differentials for a cooling system for winter and summer conditions

District cooling systems typically vary the chilled water supply temperature based on the outside ambient temperature. This temperature reset strategy will allow an increase in the chilled water supply temperature as the system cooling demand decreases, thus increasing the chiller plant efficiencies and reducing the distribution energy losses/gains. Seasonal heat gains/losses in buried chilled water distributions systems are generally small. This is due to the normally small temperature gradients between the chilled water in the pipes and the surrounding soil, particularly prevalent in northern climate zones (i.e. Canada and northern US or Scandinavia). Hence, buried district cooling piping systems are generally un-insulated, except for systems located in warmer climate zones where much higher ground temperatures are typically experienced.

It should also be noted that some caution should be taken in regards to the supply temperature reset strategy since the cooling demand is, to a great extent, also a function of the relative humidity (or wet bulb temperature). This is particularly important to keep in mind in humid climate zones where the cooling load associated with dehumidification (or latent load) could be higher than the sensible cooling load. Thus, the chilled water temperature needs to be supplied at a sufficiently low temperature to achieve the desired dehumidification of the supply air, even at lower outside ambient dry bulb temperature conditions. Another limiting factor for the potential for chilled water temperature reset is the guaranteed maximum customer supply temperature, which is

typically stipulated in the contract between the energy supplier and customer. In extreme cases, the contract is written without an allowance for any reset of the customer supply temperature (even in the middle of winter), which greatly restricts the potential for resetting the district cooling supply during low load conditions, and thus the potential for improved system energy efficiencies.

An example of a district cooling system supply temperature reset curve is shown in Figure 4.3. This example reflects an ice-based system with an outdoor design temperature of 31°C (88°F). The curve would look different for non-ice based systems and for other climatic conditions. As per this curve, the chilled water is supplied at 1°C (34°F) when the outside ambient temperature is 25°C (77°F) or higher. The supply temperature is gradually reset up to 7°C (45°F) for outside temperatures between 25°C (77°F) and 0°C (32°F) and maintained at 7°C (45°F) for outside temperatures below 0°C (32°F). Some district cooling systems would allow as high as 10°C (50°F) supply temperature during low load conditions. It is also common in some systems to control off the customer return temperature (primary or secondary side of the heat exchangers) to ensure that the desired (i.e. limit temperature outlined in the contract with the district cooling utility) is achieved at all load conditions. Some caution should be exercised with this type of control strategy due to the long response time (i.e. the water has to circulate through the whole system before the new return temperature is recorded by the return water temperature sensor). The most stable control is achieved by resetting the supply temperature based on the return temperature deviation from the return temperature limit.

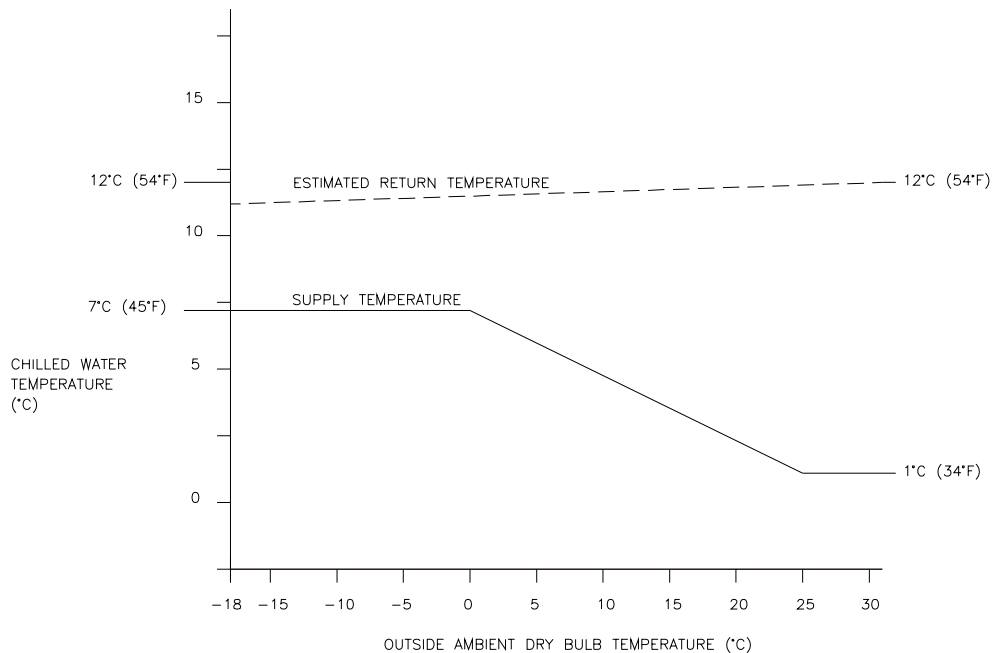

Part I Figure 4.3: Typical temperature reset of the primary water in a district cooling system

4.1.3 Customer Interface or Energy Transfer Station

Part I Figure 4.4: Typical ETS for indirect connection

The interface between the district cooling system and the building cooling system is commonly referred to as the Energy Transfer Station (ETS) in North America. In some countries, different terminology is used, for example, consumer substation. For this report, the building interface will be referred to as the ETS. The ETS consists of isolation and control valves, controllers, measurement instruments, energy meter and crossover bridge, i.e. hydraulic decoupler and/or heat exchangers (Figure 4.4 shows an



example of a typical ETS for indirect connection with two heat exchangers in parallel).

The ETS could be designed for direct or indirect connection to the district cooling distribution system. With direct connection, the district cooling water is distributed within the building directly to terminal equipment such as air handling and fan coil units, induction units, etc. An indirect connection utilizes one or multiple heat exchangers between the district system and the building system. Figure 4.5 shows an example of a basic building system schematic for an indirect connection.

Guidelines for both types of connections are addressed in Section 5 of this report with some emphasis on indirect connections.

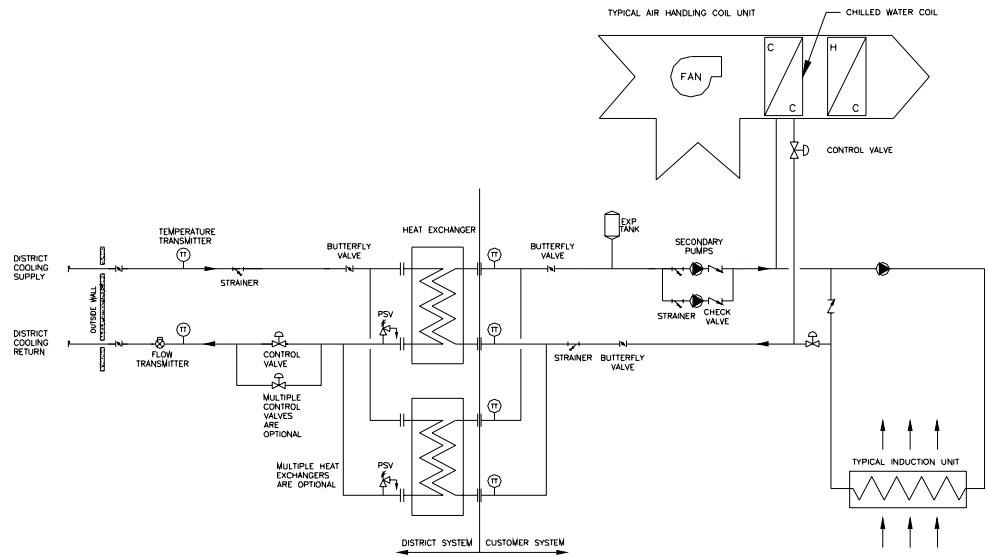

Part I Figure 4.5: Basic building cooling system schematic

Design Considerations

4.1.4 General Considerations

When planning/designing a district cooling system, it is imperative that all elements of the system, for example, the cooling source, the distribution system and energy transfer stations are integrated with the optimized system performance and economics in mind. This is done to minimize costs and to ensure that the design of all elements is consistent with the system design parameters (temperatures, pressures, etc).

The successful implementation of district heating and cooling systems depends greatly on the ability of the system to obtain high temperature differentials (ΔT 's) between the supply and return water. The significant installation costs associated with a central distribution piping system, and the physical operating limitations (i.e., pressures and temperatures) of district energy systems, require careful scrutiny of the design options available for new and existing buildings HVAC systems connected to a district energy system. It is crucial to ensure that the central district energy system can operate with reasonable size distribution piping and pumps to minimize the pumping energy requirements. Generally, it is most cost-effective to design for a high ΔT in the district cooling system because this allows for smaller pipe sizes in the distribution system. These savings, however, must be weighted against higher building conversion costs, which may result from a requirement for a high primary return temperature.

Control of the ΔT 's becomes particularly critical for district cooling systems since they operate with significantly lower ΔT 's than hot water based district heating systems (which typically operate with design ΔT 's ≥ 40 °C). The minimum supply temperature for a system utilizing (ice-

based) thermal storage and ice chillers is approximately 1°C (34°F). Without the ice, for example, centrifugal water chillers only, the supply temperature is typically limited to 4°C (39°F). The corresponding return temperature, based on the experience from North American district cooling systems, is at best 12°C (54°F) at peak operating conditions. The maximum system ΔT is thereby only 11°C (20°F) at peak conditions for ice based systems and 8°C (15°F) for conventional chiller based systems.

The system design ΔT is controlled at the customer's ETS, not at the plant. In order to optimize the system ΔT , the flow from the plant will vary. Varying the flow also saves pump energy for the district cooling system, especially with a variable speed pumping configuration. Variable flow operation is also required in the customer HVAC system in order to maintain high ΔT 's at partial load conditions.

Any deviation from the design ΔT could have significant efficiency and operational implications. The low " ΔT syndrome" encountered in almost every "real world" central chilled water system is further discussed in Section 5 of this report.

The majority of district cooling systems in North America, providing chilled water for mainly air conditioning needs, are designed for a maximum pressure of 1030 kPa (150 psig) and a supply temperature between 1°C (34°F) and 4°C (39°F).

4.1.5 Cooling Sources

The cooling source can be either directly connected to the distribution system or indirectly connected through heat exchanger(s). The direct system is limited to use where water is the distribution medium and where the water quality and pressure requirements are the same for the cooling source and the distribution system. Indirect connection allows the cooling source and distribution system to be operated as separate systems with different temperatures and pressures, allowing more design flexibility for both systems.

4.1.5.1 Vapour-Compression Chillers

Vapour-compression chillers can be driven by electricity, turbines or reciprocating engines. The electric driven (centrifugal or screw compressor) chillers are the most common in central chilled water applications. The mechanical chillers would utilize R22, R-134a, R-123 or ammonia (in positive displacement machines). Both R22 and R134a have a relatively high global warming potential, and may be phased out in the future. At this time, only R22 has a time limit set for its use (~2015). No time limit is yet in place for R134a.

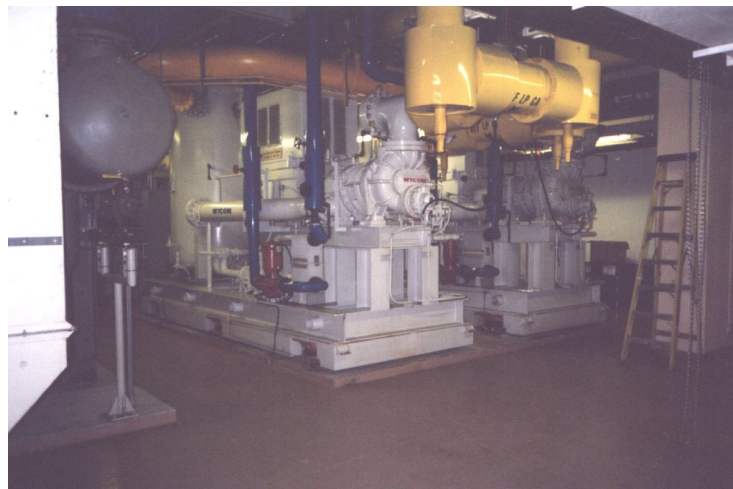

Part I Figure 4.6: Typical screw compressor (courtesy of Mycom)

Typical Coefficient of Performance (or COP) of conventional mechanical chillers is in the range of 4.0 to 5.0.

Chilled water systems can be configured with thermal storage to reduce the chillers' equipment requirements and lower operating costs by shifting peak load to off-peak times. Chilled water storage systems are generally limited to a temperature of 4°C due to density considerations. Ice-based storage systems can achieve temperatures as low as 1°C. The lower temperature available in combination with the latent capacity from the ice melting reduces the volume of the ice-tank significantly compared to a conventional chilled water tank. Thermal storage is described in more detail in Section 4.1.5.5.

4.1.5.2 Absorption Chillers

Absorption chillers may be classified as indirect fired or direct fired, in reference to their source of heat energy used. When absorption chillers are utilized in the context of an integrated member of a chilled water production system for a district cooling network, the use of indirect fired absorption units are generally assumed due to their ability to utilize waste or surplus heat available. Direct-fired absorption chillers will not be discussed in this narrative.

Some of the benefits of absorption machines over vapor compression chillers are:

- Lower electrical requirements for chiller operation.
- Lower sound and vibration levels during operation.
- Ability to utilize recovered heat and convert it to cooling energy.
- Refrigerant solutions typically do not pose a threat to ozone depletion of the atmosphere.

The two most common absorption systems employed in commercially available absorption chillers are Lithium Bromide (LiBr) – Water and Aqueous Ammonia solutions. In the case of the Lithium Bromide – Water solution, the water is the refrigerant, while for the Ammonia – Water solution, the ammonia is the refrigerant.

The minimum chilled water outlet temperatures that are achievable from an absorption chiller are dependent on the refrigerant system employed. A LiBr chiller can produce chilled water as low as 4°C. The ammonia water based absorption chillers may produce chilled water or media well below 0°C. The final outlet temperature is also a function of the heat input temperature level. The useable temperature levels for Lithium Bromide systems are 115°C – 205°C if a liquid is used, and 110°C – 185°C if steam or hot vapor is employed. Temperatures as low as 85°C is used for some smaller machines for waste heat applications.

The absorption chiller can be described by its number of “effects” or the number of “stages”. Effect is essentially the number of times the heat input into the chiller is used internally. Stages in an absorption chiller refer to the number of evaporator/absorber pairs operating at different temperature levels within an absorption chiller.

Typical COP's for commercially available absorption chillers range from 0.65 to 0.8 for single effect units and 0.9 to 1.2 for double effect units. Cooling output from the absorption chiller is proportional to the heat input, and therefore may be varied by varying the amount of heat input to the chiller. In addition to the heat input, a source of cooling water is required to reject heat from the unit condenser.

As in all energy production systems and their applications, technical and economic viability must be established prior to implementation. The experiences in North America regarding the use of absorption chillers for district cooling applications indicate that it is very difficult to justify the use of absorption chillers on an economic basis without a source of surplus or low cost waste heat energy for input into the chiller, or a specific technical reason that requires the use of an absorption chiller.

Some typical applications for absorption chillers in some of the North American district cooling systems involve using recovered heat from a reciprocating engine generator set, or utilizing the exhaust steam from a steam turbine generator set. In both cases, heat from a power generation process that would not normally be used in the summer, is converted and used to produce cooling.

4.1.5.3 Deep Lake Water Cooling

The term Deep Lake Cooling may be used to characterize any large physical body that could naturally act as a source of cold temperature fluid or heat sink. In the case of a water body, where the local climatic conditions and physical geometry of the water body allow the water temperature to decrease to a relatively low temperature level, the water may be withdrawn and the cooling energy extracted and used. The water would then be returned to its source.

In the northern United States and Canada, the temperature of water in a lake or stream will be variable with season at or near the surface of the water. If the lake or stream is deep enough, the temperature of the water will begin to reach a minimum temperature that is essentially constant throughout the year. Water from this temperature level may be used as a source of chilled water. The chilled deep lake water may be employed directly in building cooling systems, or indirectly by providing cooling energy through a heat exchanger to a circulating network of chilled water.

As an example of the deep lake water temperature variation with depth, Lake Ontario, which is one of the lakes in the group known as the “Great Lakes” in North America, is expected to reach a water temperature of 4°C or lower at a depth of 80 meters. This temperature is estimated to vary by 1°C over the course of a year. This temperature characteristic, at 80 meters of depth, has prompted various studies and conceptual designs to be produced with the goal of determining how best to utilize the chilled lake water for cooling buildings in the City of Toronto, Ontario, Canada.

This source of cooling energy could displace many kWh of electricity consumed in the operation of electric vapor compression chiller systems as well as minimize the amount of refrigerants employed within the City of Toronto itself.

In addition to the technical issues, the return of warmer water to the lake and its impact on the local ecosystem must also be evaluated.

In the Stockholm region of Sweden, several lake water cooling projects have been constructed over the last five years, both from salt water and fresh water lakes. These systems are isolated from the district cooling systems via heat exchangers. The chilled water temperatures achieved from the “free cooling” source varies from 7 to 9°C during the cooling season. Most systems utilize conventional chillers or heat pumps to supplement the lake water cooling.

4.1.5.4 Ice slurry

The concept of ice slurry cooling is relatively new in North America and no commercial-scale systems are currently in operation. The concept involves making ice slush at a central plant and pumping a 5-to-50%-ice crystals-to-water mixture through a piping system to the end users. This ice slurry mixture consists of a solvent and a solute. The solvent is commonly water and the solute propylene glycol (5 to 10%). The main benefit of using an ice slurry working fluid is its high transport energy density. The ice slurry system utilizes both sensible and latent energy transfer. The latent energy is released during the phase change when the ice crystals in the slurry are melted to liquid water.

One of the challenges with this type of technology is related to the pumping of the slurry and to the design of the interface at the user end. In particular, for district cooling applications with extensive piping networks, pumping over long distances could create complicated system hydraulics. Equipment must be designed to accept the ice, water and glycol mixture. The costs of ice making versus lowered distribution costs have to be considered carefully.

4.1.5.5 Thermal Storage

District cooling systems can be configured with thermal storage to reduce chillers’ equipment requirements and lower operating costs by shifting peak load to off-peak times. The cool storage is most commonly sized to shift part of the cooling load, which allows the chillers to be sized closer to the average load than the peak load. Many electric utilities offer lower rates during off peak periods, and thus operating costs for electric-driven chillers can be substantially reduced by shifting some loads to off-peak periods.

Both ice and chilled water storage are used in district cooling plants. Chilled water storage systems are generally limited to a temperature of 4°C due to density considerations. Ice-based storage systems can achieve temperatures of 0.5 - 1°C. The ice storage systems require refrigeration equipment operating below 0°C (32°F), normal range –9 to –3°C (15 to 26°F). The

heat transfer fluid for ice making may be a refrigerant or a secondary coolant, such as glycol or some other antifreeze solution.

The storage volume depends on the temperature difference (ΔT) between the water supplied from the storage and the return water. For most systems, the maximum delta is 11°C (20°F). The storage volume of chilled water storage is also affected by the degree of separation maintained between the stored cold water and the warm water return. This fact is particularly important for “stratified” chilled water storages, which rely on the tendency of water to form horizontal layers or temperature zones (i.e. isotherms) based on the density of water. Ice thermal storage uses the latent heat of fusion of water. The storage volume depends on the final proportion of the ice to water in a fully charged tank. The ice storage requires ¼ or less volume than chilled water storage for the same capacity. The ice making chillers, on the other hand, operate with lower efficiencies than conventional chillers (COP’s in the range 2.5 to 4.1 Vs 5.0 to 5.9 for chilled water⁹). Thus, the economic benefits with ice storage systems rely, to a great extent, on the lower off-peak electrical rates.

4.1.6 Distribution

The thermal capacity of the district cooling system is determined by both the rate of water flow and the temperature differential (ΔT). A large ΔT allows for the use of smaller pipes, which reduces the capital investment for construction of the system. The system operating efficiency also increases with an increased ΔT due to the reduced pumping requirements caused by the reduced flow rates and the reduced heat gains/losses in the distribution system.

To illustrate this with an example, Figure 4.7 shows the relationship between ΔT and pipe size. The example illustrated in the figure shows that the pipe size, based on a constant pressure gradient of 150 Pa/m, decreases from 800 millimeters (32 inches) to 600 millimeters (24 inches) when the temperature differential increases from 5°C (9°F) to 11°C (20°F) for a load of 50 MW (~14,000 tons). The peak pumping requirements (i.e. horsepower) would be reduced by over 50% with the increased ΔT .

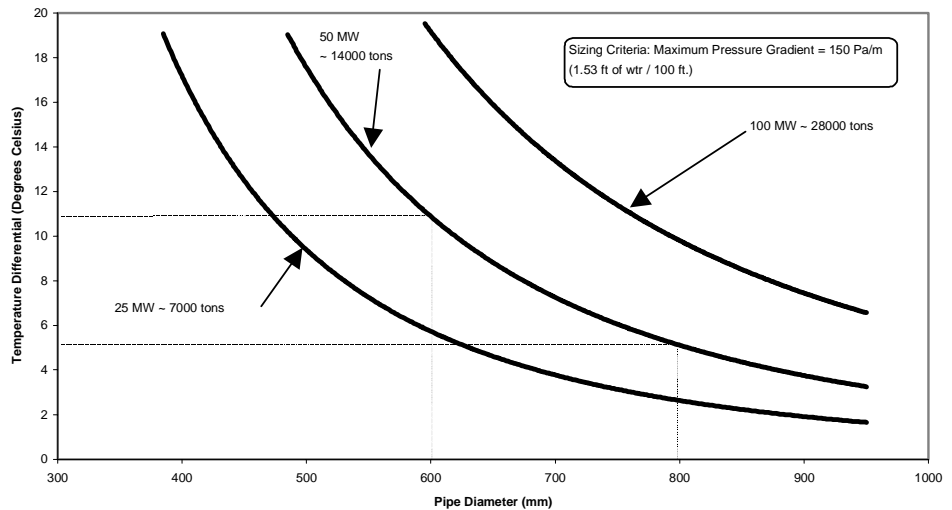

Part I Figure 4.7: Temperature differentials versus pipe diameter

The pipe sizing criteria for the distribution piping system design is governed by the following four key factors:

- The system ΔT .
- Maximum allowable flow velocity.
- Distribution network pressure at the design load conditions.

- Minimum differential pressure requirements to service the most remote customer.

The system ΔT , as previously discussed, is typically limited to 8 - 11°C. The maximum allowable flow velocities are governed by pressure drop constraints and critical system disturbances caused by transient phenomena (i.e., water hammer effects). Generally, velocities higher than 2.5 – 3.0 m/s (8-10 ft/sec.) should be avoided unless the system is specially designed and protected to allow for higher flow velocities.

The piping material commonly used in district cooling systems is welded steel or polyethylene (HDPE) piping. Both types of piping material can normally accommodate the required working pressures and flow velocities. From an operational point of view, both types of piping systems are welded, which provides a watertight solution. Other types of material used are mechanical jointed systems like FRP-piping, PVC or ductile iron.



Part I Figure 4.8: Typical direct buried piping installation

Direct buried distribution piping systems are normally installed un-insulated since the thermal heat gains/losses from/to the surrounding soil are generally insignificant given the low ground temperatures at the buried depth (larger than 600 mm) typically encountered. However, there could be some potential for excessive temperature degradation in the smaller line sizes (in particular buildings' service lines) during the cooling season. Therefore, these lines may have to be insulated. Also, in warmer climate zones, it may be necessary to fully insulate the piping system to avoid excessive heat gains and associated temperature degradation in the piping system. Special considerations should be taken to the start-up phase of a new system if only a few customers are connected. Since the distribution system typically would be sized for a maximum load much higher than the initial first phases, the flow velocities in the main lines could initially be significantly lower than the design flow velocities. This could cause excessive temperature degradation of the final chilled water supply temperature received at the customer end (ETS). One way to get around this problem is to design for a higher primary chilled water supply temperature for the initial customers. However, if the temperature degradation is too excessive, it may be necessary to insulate part or all of the supply lines. Non-buried distribution piping should always be insulated and have an adequate vapour barrier to avoid condensation on the piping surface.

4.1.7 Energy Transfer Stations

It is imperative that the building chilled water system is capable of providing high return temperatures at all load conditions, thereby ensuring optimum district cooling return temperatures. In order to achieve this, the terminal equipment (i.e., AHU coils, fan coil units, etc.) should be designed for a high ΔT and for variable flow operation. Furthermore, the building side chilled water supply temperature should be reset based on outside ambient temperature, for example, variable supply temperature, similar to the reset curve shown in Figure 4.3. This helps to optimize the district cooling system economics and allows customer savings (capital and operating) through reductions in pipe sizes, smaller pumps, and reduced pumping requirements (reduced kWh usage).

Benefits of District Cooling Systems

A district cooling system can offer significant benefits to a community. The three groups most likely to benefit from district energy in a community are property/building owners, the municipality, and society at large.

4.1.8 Property / Building Owners

A district cooling system allows the building owner to eliminate their on-site chiller operation and maintenance. By doing this, the building owner no longer needs to purchase utilities, operate and maintain chillers, and replace chillers at the end of their life cycles. Because of the high efficiencies that district cooling systems operate at, and their ability to utilize inexpensive or waste energy sources, the building owners can expect more stability in their energy costs into the future.

For future buildings that are constructed, the overall capital costs are reduced, when the cost of the chiller room is eliminated; or the space allocated to the building chiller may be converted to revenue generating space. The cost of insurance should also be reduced to reflect the lower risk.

District cooling systems are built with standby cooling capacity to ensure that cooling is always available at the central plant. Distribution systems are generally designed with multiple loops or other back-up to provide additional reliability in distribution. Overall, the reliability provided by a properly designed and constructed district cooling system is greater than most buildings can achieve individually.

4.1.9 Municipalities

A district cooling system also provides significant benefits to the municipalities where they are built. The most obvious benefit to the municipality is the significant amount of infrastructure that will be added to the community. This infrastructure will give the community a competitive edge in attracting new development over other communities who do not have district energy systems.

A benefit that is often overlooked is the ability of a district cooling system to capture cash flows that were previously leaving the community. Typically, energy expenditures leave the community to pay for the natural gas and electricity that is imported. A district cooling system service expands the opportunities of using local energy sources like combined heat and power to keep more of the money, currently being spent on energy, circulating within the community.

4.1.10 Society

The development of a district cooling system is a response to the need to provide energy for the future in a manner that is consistent with the need to protect our environment. The production of cooling from a centralized facility allows for improvements in energy conservation. Energy conservation and the wise use of fuel sources are the most cost-effective ways available to us to reduce atmospheric emissions, global warming, and the release of ozone depleting gases. Not only can the quality of life be maintained without a significant increase in the cost of energy, but also the initiative is in line with meeting the international protocols for a positive reduction of nitrogen oxides (NO_x) and carbon dioxide (CO₂).

The underlying principles adopted for district energy are to provide a cost-effective, reliable, efficient and environmentally friendly service which not only benefits the customer, but also the public at large through lower emissions of NO_x and CO₂ in the production of cooling.

5 Designing For Interface With District Cooling

Introduction

This chapter describes key points in designing the interface between the building cooling system and the district cooling system, defined as the energy transfer station, and discusses building system design elements that are of relevance regardless of the type of building cooling system. This material is intended for use in the design of new building systems as well as for conversion of existing building cooling systems.

Section 5.2 describes, in detail, the components of a typical energy transfer station used for indirect connections.

Section 5.3 describes in more general terms the direct connection of building systems to the district system including guidelines for determining the criteria when direct connection could be considered.

The discussion of secondary systems in Section 5.4 is oriented toward large building systems but is a useful reference for all buildings.

All ETS equipment is selected, based on the contract peak demand load for the buildings. It is important that this value is as accurate as possible to avoid over-sizing the ETS. Normally, the customer is charged a monthly demand charge (i.e. \$/kW) based on the stipulated contract demand. Thus, it is in the customer's best interest not to overestimate the building peak load.

Energy Transfer Station – Indirect Connection

5.1.1 Heat Exchangers

The heat exchanger is one of the major components of the energy transfer station. It is therefore essential that the heat exchangers be carefully selected to provide the duty required, based on the temperature differential (ΔT) and pressure differential (DP) requirements dictated by the specific district cooling system as well as by local code requirements. In North America, it is quite common for district cooling utilities to select or even provide the heat exchangers. In some instances, the customer provides their own heat exchangers in accordance with a set of design parameters, often outlined in an Owner Requirement Specification issued by the utility.

The allowable pressure drop (DP) across the heat exchanger is one of the critical parameters to be considered for the selection criteria. The higher the pressure drops, the smaller and less expensive the heat exchangers will be. However, the DP should typically not exceed the chiller evaporator pressure drop if the building's existing pumps are to be reused. If the DP is higher over the heat exchanger than the chiller evaporator, the system curve will be altered from the design conditions, which could cause flow-balancing distortions in the secondary system. Another important consideration is the temperature approach, for example, differences between the heat exchanger's district cooling side and the building side temperatures. As discussed in Chapter 2, it is of utmost importance that the system operates with a maximized ΔT . Based on this, a close temperature approach is required to minimize the temperature "loss" over the heat exchanger.

Plate heat exchangers, also known as plate-and-frame heat exchangers, as shown in Figure 5.1, or flat plate heat exchangers, are the only type of heat exchangers that can provide a close temperature approach (less or equal to 1°C). Brazed plate heat exchangers, another type of plate heat exchangers without gaskets, could also be used for small buildings. Other types of heat exchangers, i.e. shell & tube or shell & coil, are not typically suitable for district cooling applications since the required close temperature approach cannot be achieved with these units. The physical sizes of these units would also be much larger compared to the plate heat exchangers.

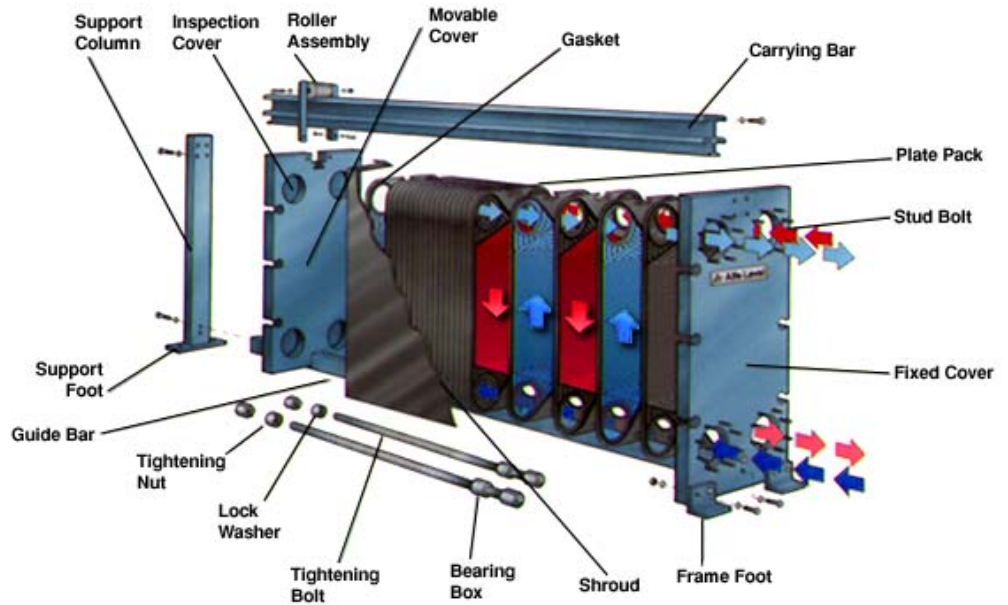

Part I Figure 5.1: Picture of typical PHE (courtesy of Alfa Laval)

In some cases, it may be necessary from a size restriction and/or reliability point of view, to install two heat exchangers (each designed for about 50-75% of the load). This also tends to improve the partial load performance; however, the capital cost will be higher. The redundancy requirements are typically determined on an individual customer basis. Generally, the redundancy requirements are less for a building serviced by district cooling compared to individual chiller operation since a heat exchanger has no moving parts, and will not “break down” like a chiller could.

When heat exchangers are connected in parallel for uniform load (see Figure 5.2), balancing valves are normally not required. However, isolation or shut-off valves for each heat exchanger are required for preventive maintenance and emergency work. Adequate clearance must be available on the sides of the units to remove/add plates for cleaning.

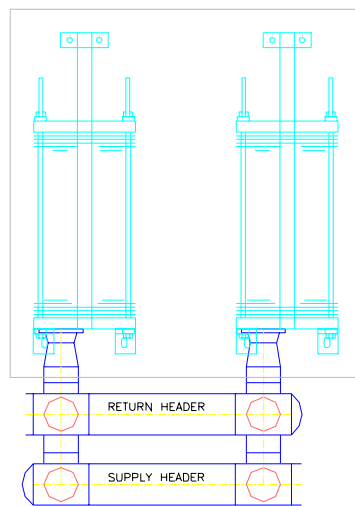

LAYOUT VIEW FOR CONNECTION OF MULTIPLE HEAT EXCHANGERS

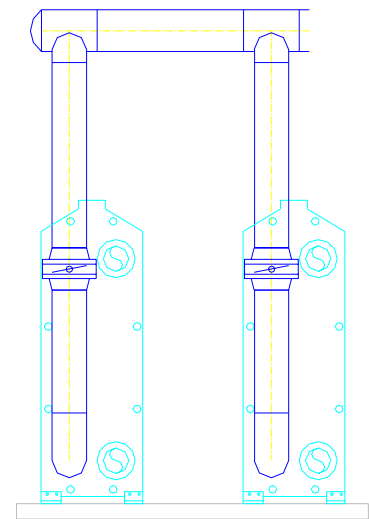

FRONT VIEW FOR CONNECTION OF MULTIPLE HEAT EXCHANGERS

Part I Figure 5.2: Principal connection methods for uniform flow

The required design pressure on the cold side (district side) of the plate heat exchanger is typically 1000 kPa (150 psig). On the warm side, the building chilled water system pressure will determine the design pressure classification. High-rise structures may have design pressures exceeding 2000 kPa (300 psig). Several plate heat exchanger manufacturers can meet the high pressure

requirements. No special consideration to the gasket material is normally required for district cooling applications due to the low temperatures and small ΔT variations.

Pipe strainers with screen/mesh as per manufacturer's recommendation must be installed at the plate exchanger inlets to protect them from grit and debris.

5.1.2 Heat Exchanger Performance

Variable flow on both sides of the heat exchanger is required in order to maintain a high system ΔT at all load conditions. The following example illustrates what happens if the customer side of the heat exchanger is constant flow and the district side is variable.

The performance of a heat exchanger is a function of several factors i.e. the flow rate, logarithmic mean temperature difference (or ΔT), etc. Thus, the capacity is a non-linear function of the flow rate due to the impact of the ΔT . The effect of the non-linearity on the performance profile can best be shown with an example. Figure 5.3 shows the constant secondary flow scenario and Figure 5.4 shows the variable flow scenario.

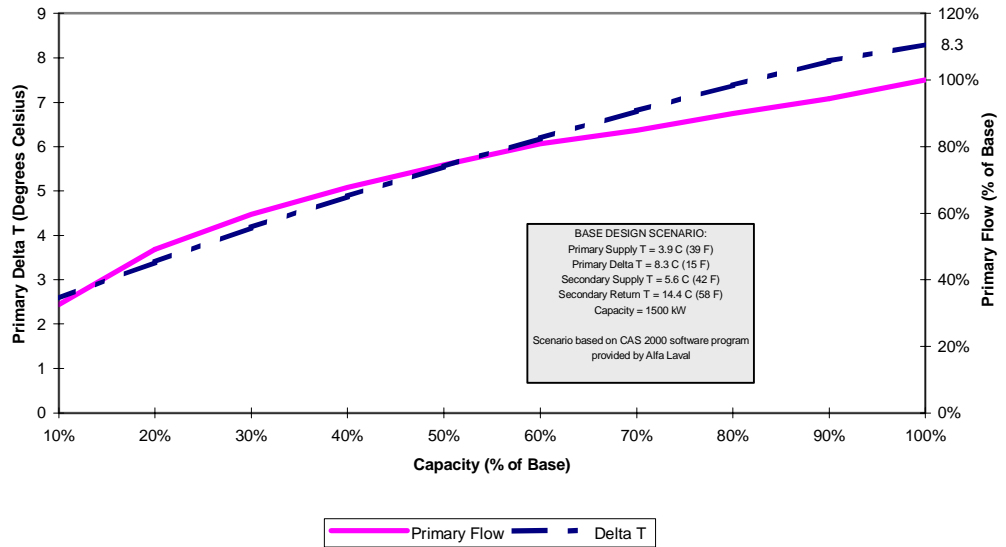

Part I Figure 5.3: PHE performance with variable primary flow and constant secondary flow

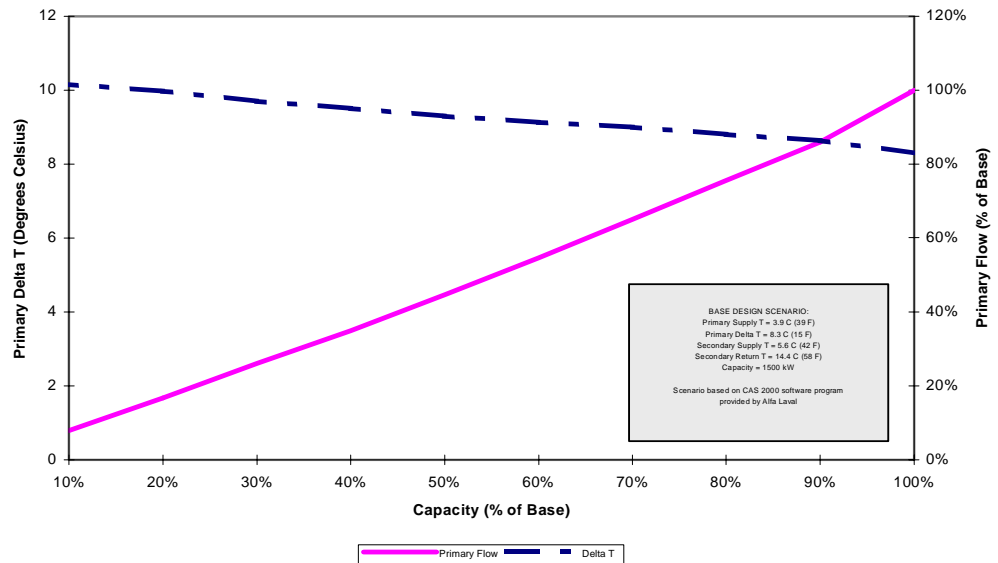

Part I Figure 5.4: PHE performance with variable primary and secondary flows

As can be seen from Figure 5.3, at a building load of 50% of design load and constant customer side flow, the required district cooling flow rate would be 75% of the maximum flow and the resulting ΔT would be 5.6°C compared to the 8.3°C design ΔT . For the same building load with variable flow (Figure 5.4) in the customer system, the required flow rate would be 45% of maximum and the resulting ΔT 9.3°C, which is even higher than the 8.3°C design. This example clearly shows the importance of having variable flow on both sides of the heat exchangers.

5.1.3 Controls

The controls are another major component of the energy transfer station. A great deal of emphasis should be given to the selection of control valves and control strategy to ensure optimum functioning controls. The objective of the controls is to maintain correct chilled water supply temperature to the customer and at the same time, provide high return back to the district system.

District cooling systems should be designed so that the primary and secondary water temperatures vary according to the outdoor temperature (similar to curve shown in Figure 5.5). This control strategy will reduce energy costs and optimize conditions for the control valves, while maintaining comfortable interior temperatures. The key control components for a typical energy transfer station are shown in Figure 5.5.

The wide range of flows, pressures, and load turndown requires special considerations in the selection of control valves. The control valves must be selected for sufficient pressure drops to provide high control authority. A “rule of thumb” is that the pressure drop across the control valve, at fully open position, should be at least equal to the total pressure drop across the heat exchanger, flow meter, and associated piping and equipment. If information on the actual differential pressure (DP) conditions at each ETS is readily available from the district cooling utility, this information should be used to size the control valves in lieu of the “rule of thumb” above. The control valve should have a pressure drop through the valve equal to at least 50% of the total available system DP. Ideally, the relationship between valve travel and heat exchanger output should be linear. Valves with an equal percentage characteristic do normally perform well for this application. ETS’s closer to the district cooling plants would have to withstand a higher DP.

It is essential that the control valves be selected to match the building’s actual thermal loads as closely as possible. Oversizing reduces valve life and causes valve hunting. Control valves should be selected with high rangeability, low leakage, and proportional plus integrating control for close adjustment, accuracy and response time. Control valve actuators should have enough power to

open and close under the maximum pressure differential in the system, and should be selected to perform well with the characteristics of the heat exchanger.

For larger flow rates (larger than 5 l/s), it is advisable to use two valves connected in parallel and operating in sequence. For best control in most cases, the two valves should be sized to handle one-third and two-thirds of the total capacity. When redundancy requirements are high, for example, multiple heat exchangers in parallel, it may be advantageous to install separate control equipment for each heat exchanger to provide a better turndown ratio and equal heat exchanger loading. However, this could add significantly to the cost of the controls, and thus may not be justified.

Electrically actuated control valves should remain in a fixed (last) position upon power failure, and should have a manual override function. Pneumatic actuated control valves should fail open upon loss of air pressure.

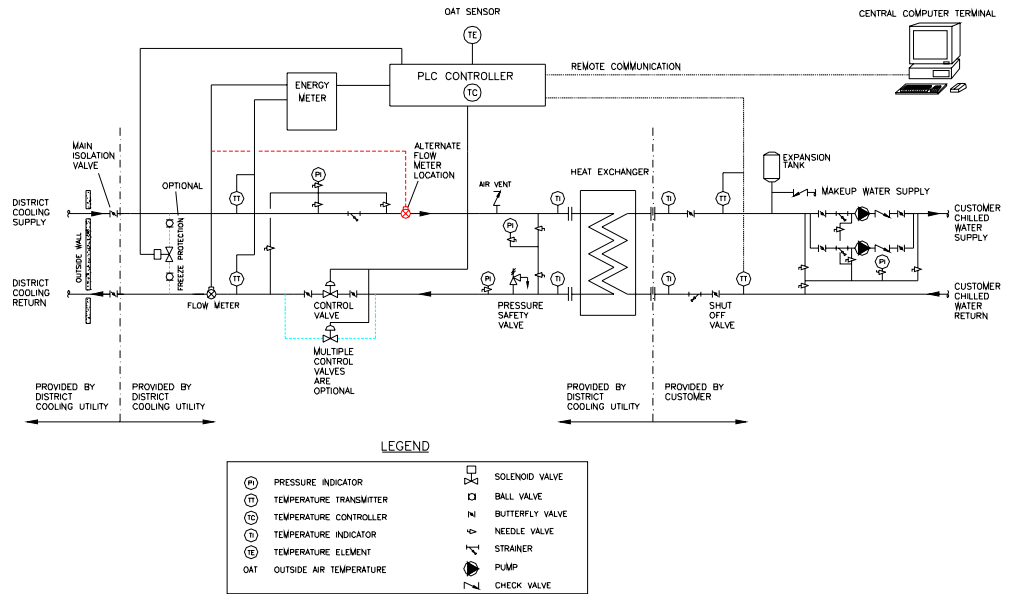

Part I Figure 5.5: Heat exchanger and associated components

The control valves are normally installed in the return line. However, it is also fully acceptable to install the valves in the supply line since the risk of cavitation is small in district cooling applications. However, it is important to note that the control valves are for temperature control and are not intended to be used as pressure reducing valves.

Primary control valves are one of the most important single elements in the interface with the district cooling system, and proper valve adjustment and calibration will save energy. High quality, industrial grade control valves should be selected for more precise control, longer service life and minimum maintenance.

Microprocessor-based electronic control systems, either direct digital control (DDC) or programmable logical control (PLC), are used for control, monitoring, and data acquisition at the energy transfer stations (ETS). With the advances in the building automation industry over the last decade, it has become more common for district energy systems in North America to incorporate full remote control and monitoring capabilities into the ETS design, often integrated with remote energy metering. The remote control and metering is done by way of a communication network via conventional cable, fiber optics, modem, or radio. The controls contractor typically provides a “turnkey” for the controls and metering, including installation and commissioning of the communication network. The control panel can be prefabricated and pre-wired to simplify the on-site installation and wiring. Figure 5.6 shows a typical prefabricated ETS control panel with the operator panel and energy meters installed in the front door panel.



Part I Figure 5.6: ETS panel photo (courtesy of Thermal Automation Canada)

5.1.4 Energy Meters

*Introduction*² - The energy meter registers the quantity of energy transferred from the user's secondary system to the primary system. Cooling energy is the product of mass flow, temperature difference, the specific heat of the water, and time. It is difficult to measure mass flow in an enclosed pipe system, so volume flow is measured. The result is corrected for the density and specific heat capacity of the water, which depends on its temperature. The effect of pressure is so small that it can be neglected.

An energy meter consists of a flow meter, a pair of temperature sensors, and an energy calculator that integrates the flow, temperature data and correction factors. It is desirable that the energy meter be supplied as a complete unit; factory calibrated with stated accuracy performance ratings in compliance with accepted metering standards.

Meter Types – The following are brief descriptions of the most common flow meters suitable for district cooling use. Meters can be divided into two major groups: dynamic meters, which register flow with the aid of moving parts; and static meters, which have no moving parts.

5.1.4.1 Dynamic Meters

There are two types of dynamic meters used in district cooling: impeller and turbine meters.

Impeller meters measure flow with the aid of straight-bladed impellers. There are two types of impeller meters: multi-jet and single-jet.

Multi-jet impeller meters are very sensitive to impurities such as sand and sharp metal particles, but are not sensitive to flow disturbances. This type of meter is best suited to medium-sized buildings but not for small buildings because it does not function well at small loads.

In single-jet impeller meters, the flow runs through a single nozzle directed tangentially to the impeller blades. Single-jet meters have properties similar to those of multi-jet meters, but they are more suitable for small buildings because a very weak flow is enough to start the meter.

In a **turbine meter**, the flow is always in the direction of the rotor shaft. “Woltmann” and “rotary vane” meters are types of turbine meters. The accuracy of the meter depends on the flow profile before the meter; so strong flow disturbances must be avoided. The flow is directed to the rotor blades via fins.

² The discussion on energy meters, particularly meter types, draws extensively from “IEA District Heating – Guidelines for Converting Building heating Systems for Hot Water District Heating” (1).

The weaknesses of this meter are its high start-up threshold and rapid wearing of bearings at high loads and in dirty water. Turbine meters are suitable for high flows, but are not suitable for small buildings.

5.1.4.2 Static Flow Meters

There are two types of static flow meters which are used in district cooling applications: magnetic induction (MID) and ultrasonic.

The **MID meter** is based on the induction of voltage in a conductor moving in a magnetic field. The conductor in this case is water. The recommended conductivity is $\geq 5\mu\text{S}/\text{cm}$. Generally, district cooling water is conductive enough for MID metering. However, it is essential that this be confirmed in each specific case. Furthermore, the magnetite content of the water should also be checked to verify that the recommended value of 0.1 mg/kg (maximum) is not exceeded.

The water flows through a pipe made of non-magnetic material with an exactly known cross-sectional area. Electrodes connected to powerful electromagnets sense the flow. The voltage induced in the water is measured and amplified and the information is converted by the heat calculator.

Experience with MID meters in district cooling has been good. Although their initial cost is higher than dynamic meters, consideration should be given to their reduced maintenance and increased accuracy.

Ultrasonic metering is based on changes in the propagation of ultrasonic waves caused by the velocity of the flow. These changes are registered by measuring the time between the transmission and reception of ultrasonic signals over an exactly known distance, or by measuring changes in the frequency of reflected ultrasonic waves.

Recent experience indicates that ultrasonic meters are accurate and cost-effective for large flows.

Designing for Meter Installation and Maintenance - The flow meter could be installed in either the primary supply or return pipe (see Figure 5.7). In some instances, it may be beneficial to install the meter upstream of the heat exchanger and control valves to minimize the possible formation of bubbles in the flow stream, which could affect the meter accuracy. In most cases for dynamic meters, to ensure uniform flow and accurate flow measurements, there should be a length of straight pipe 10 times the pipe diameter before the flow meter, and a length of straight pipe five times the pipe diameter after the flow meter. This requirement is typically reduced to half the distance for static meters installed with reduced pipe size diameter. The district cooling utility and meter manufacturer should be consulted for specific instructions.

Flow meters should not be installed in the low point of the piping system where dirt accumulates. Similarly, they should not be installed in the piping at the high point of the system, which would cause air to accumulate in the meter. To reduce wear on the bearings of a dynamic meter, it is important to fit the meter so that its impeller shaft is vertical. For magnetic meters, the pipes have to be grounded. Signal cables should be well protected from external disturbances.

Temperature sensors should always be installed against the flow, with the tip of the probe situated approximately in the center of the pipe. In addition, a properly sized measurement housing for the sensor and the water thermometer should be installed in the primary piping. Pipe increasers or a measurement housing will not be needed when sensor wells can be installed in pipe elbows or when pipe diameters exceed 100 mm (4 inches). In smaller pipes, wells for heat meter sensors can obstruct the flow. The sensors' surroundings should always be heat-insulated; otherwise, heat loss/gain from the sensors distorts the measurement. The sensors' wires should be of exactly the same length, for example, matched pair, unless four-wire metering is used.

A MID meter should be fitted so that it is as easy as possible to clean the pipe and electrodes. Dirt on the electrodes creates an extra resistance that causes errors in the voltage measurement.

MID meters are not very sensitive to flow disturbances. Manufacturers state that a disturbance-free section of pipe, five times its diameter before the sensor, is enough. They also recommend that a pipe section two times its diameter should be free from disturbances after the sensor. However, any meter is more accurate if the disturbance-free sections of pipe are longer than the recommended minimums.

Meters are generally supplied and installed under the supervision of the utility company. The utility may also supply a temporary spool piece, the same size as the meter, for installation in lieu of a meter until the system is clean and ready for operation or if the meter is removed for recalibration. Meter selection and sizing shall be verified by the utility, based on the information supplied by the ETS design engineer. For proper meter selection, it is essential that the utility understands the building system operations under maximum and minimum flow conditions.

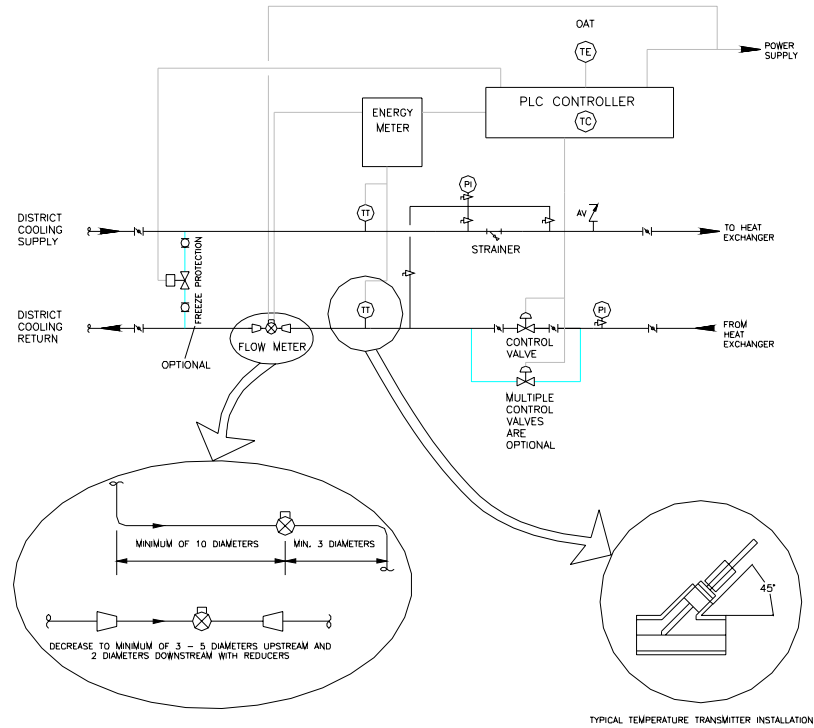

Part I Figure 5.7: Typical installation of the energy meter

Part I Figure 5.8: Magnetic inductive flow meter (courtesy of Endress & Hauser)



North American Experience – The magnetic inductive (or magmeter) has become the preferred flow meter in several district cooling systems in North America. The excellent accuracy, low pressure drops, good rangeability, as well as low maintenance can normally justify the higher cost for magmeters compared to most dynamic type meters. Figure 5.8 shows a typical industrial standard magmeter suitable for district energy applications.

There are currently no performance standards in place for thermal meters in North America. However, there is an increasing awareness, both from customers and utilities, that a standard would be beneficial to the industry. There are international standards in place like the OIML-R75 and the European Standard EN 1434 that could be used as references.

5.1.5 Other Equipment

Pressure gauges, thermometers and shut-off valves should be installed to enable proper monitoring, balancing and equipment isolation for maintenance (see Figure 5.5.).

A strainer with a mesh of 1.2 mm (3/64 inch) or smaller, must be installed to adequately protect the critical components (i.e. heat exchanger, flow meter, and control valves). In order to determine when the strainer should be cleaned, a pressure gauge should be connected to both sides of the

strainer (see Figure 5.5). The pressure drop through the strainer must be considered in the system design.

5.1.6 Location of Energy Transfer Station

The district cooling utility, in conjunction with the customer, should be consulted to determine a suitable location for the energy transfer station and routing piping. Factors to be considered are the location of the primary system distribution piping and maximum allowable elevation of the ETS and associated primary piping. The latter is very important since the system would have to be pressurized to maintain a positive static pressure throughout the system. A high system static pressure requirement will limit the maximum potential dynamic pressure in the system, and consequently limit the system capacity.

The ETS, should preferably be located at the basement or ground floor level, adjacent to an outside wall. Most commercial high-rise structures in North America have the chiller plants located at the penthouse level. Consequently, the chiller room is typically not a suitable location for the ETS. Rather, suitable space has to be found closer to the ground level, possibly in an underground parking garage, storage area or mechanical rooms located on a lower level of the building. Furthermore, a routing would have to be found for the interconnecting piping from the ETS to the existing secondary piping system headers. The room size should meet the local building code, and be serviced by city water and drainage as well as power at suitable voltage and amperage. The equipment should be accessible for inspection and maintenance, including disconnection and removal of equipment for repair or replacement. Personnel from the utility must be able to enter the room unassisted, but the room should be locked to keep out unauthorized personnel.

Energy Transfer Station - Direct Connection

Direct connection of the customer's terminal cooling equipment (such as cooling coils, induction systems, etc.) to the primary distribution system is in some cases more economical than the indirect method. In fact, the majority of the district cooling systems operating in North America use direct connections or a mix of both direct and indirect connections. Direct connection should especially be considered in new development areas where buildings' cooling systems could be specifically designed for direct connection. Direct connection utilizes primary/secondary pumping where the chilled water is pumped from the primary system (district cooling) to the secondary system via a bypass bridge or decoupler. Figure 5.9 shows a typical direct connection. The guidelines outlined for indirect connections, including equipment selections, are also generally applicable for direct connections.

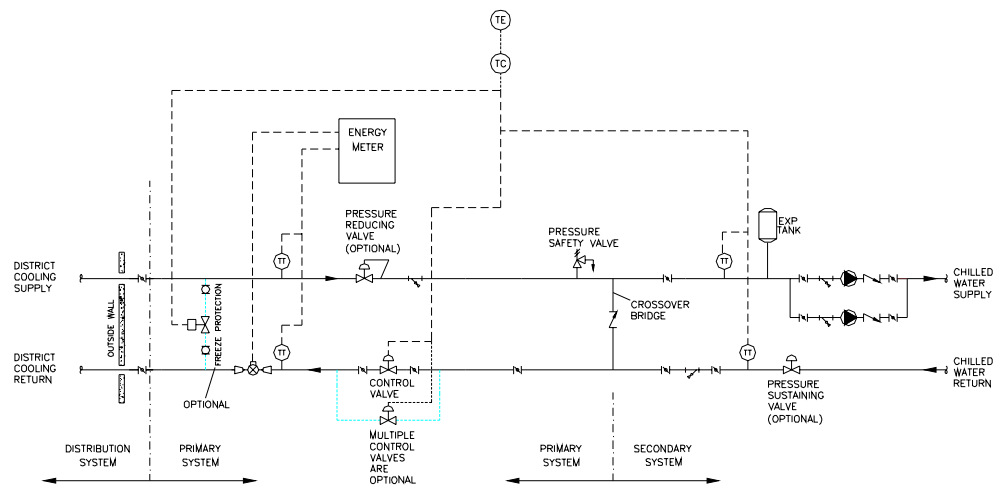

Part I Figure 5.9: Direct connection of building system to the district cooling system

When designing a direct system, care must be taken to protect the safety of the customer installation and the reliability of the district cooling system. Some of the advantages and disadvantages with direct connections are summarized as follows:

Advantages:

- Capital savings through elimination of heat exchangers and associated equipment, and water treatment systems, for example, water treatment would be provided at the central plant.
- Reduced ETS space requirements.
- Potential increased system ΔT , which could reduce the distribution system capital investment cost and pumping requirements.
- Reduced equipment maintenance and potential shutdowns for cleaning of heat exchangers.

Disadvantages:

- Building design pressure has to be designed for the same pressure as the district cooling system, normally 1000 kPa (150 psig), which could add capital to the secondary system.
- Direct connection increases the opportunities for damage or cross contamination, which could affect the entire system (both primary and secondary).
- Building specific water treatment requirements may not be met (i.e. water treatment provided at the central plant only).

Depending on the size and design of the main system, elevation differences, types of customers and building systems, additional safety equipment such as pressure reducing valves in the supply line and pressure sustaining valves in the return line may be required.

Direct connection is most suitable for smaller district cooling systems and/or where the static head in the distribution system is low, which is the case in areas with relatively flat ground and low-rise buildings. The feasibility of direct systems is also enhanced where most of the buildings to be served are designed and built with direct district cooling in mind.

5.1.7 ETS Connection Criteria

The following general criteria could be used for determining indirect or direct connection of the customers for a district cooling system with a design pressure of 1000 kPa (150 psig). Generally, buildings designed for a minimum of 150 psig can be directly connected, and buildings designed for a lower pressure will have to be isolated via heat exchangers. A combination of direct and indirect is also possible, where practical, to connect the lower floors (normally the first 15 – 17th floors (or approximately 60 meters [200 feet] elevation) of the buildings directly (i.e. up to an elevation corresponding to the return pressure in the distribution system), and indirectly (via heat exchangers) for any floors above the 15-17th floor. In no case shall the customer's building exert a static pressure on the distribution system greater than the return pressure in the system. The specific connection criteria for each building are to be determined at the final design stage in coordination with the utility. The general criteria can be summarized as follows:

- Buildings with chilled water systems designed for a minimum of 1000 kPa, and with a height of no more than 60 meters (above grade or City Datum) can be direct connected.
- Buildings with chilled water systems, designed for less than 1000 kPa, must be indirectly connected or the existing system components upgraded to a higher pressure class to allow direct connection.
- Buildings with chilled water systems, designed for pressures other than 1000 kPa, with penthouse chiller locations at a height of more than 60 meters, or with basement chiller locations with operating pressures exceeding 1000 kPa (and without the possibility of isolating the upper floors) must be indirectly connected.

- Buildings with chilled water systems designed for minimum 1000 kPa and with a height exceeding 60 meters elevation (above grade), can be directly connected up to 60 meters and indirectly connected via heat exchangers for elevations exceeding 60 meters.
- Buildings that have systems contaminated with significant rust or chromates may require a heat exchanger.

The above should be regarded as guidelines only, and the actual maximum allowable building heights for direct connection is subject to detailed hydraulic analysis including static and total system pressure evaluation.

Secondary Systems

5.1.8 General Considerations

As per Section 5.3, the direct connection of the buildings' secondary systems shall only be implemented if the secondary system can meet the district cooling system design criteria. Otherwise, the building cooling system must be isolated by heat exchanger(s) from the district system.

Secondary systems are often configured with several loops, with separate pumps serving sub-circuits that supply different terminal equipment, areas or even buildings. Generally, it is acceptable to connect these loops to one (or multiples in parallel) heat exchanger (see Figure 5.10). However, there is a risk for (potential) interactivity between the loops since the pressure drop through the heat exchanger is normally fairly high (50-70 kPa). Hence, in some cases, a primary/secondary-pumping configuration with a bypass (or decoupler) between the heat exchanger units (primary) and the distribution loop (secondary) may be required to eliminate this potential interference. Alternatively, each loop would have to be supplied by separate heat exchangers. A certain degree of interactivity between the loops is normally acceptable. The "rule of thumb" is that if the ratio of the pressure drop in the common resistance, for example, heat exchangers and common piping, over the lowest pump head of the pumps in the loops concerned is ≤ 0.3 , the interactivity is normally acceptable. If this condition is met, primary pumps are generally not required. For direct connections, the loops are connected to a common small resistance (i.e., headers and bypass pipe) and thus the interactivity between the loops is negligible.

There is usually no advantage in connecting cooling loops with different temperature requirements, for example, AHU coils, radiant panels, induction units, etc., to separate heat exchangers. The different temperature requirements for respective systems are achieved using sub-circuits (shunts). As per the above, separate systems may be advantageous when interactivity (between the various loops) could be a concern or when an added redundancy is required from a building operating perspective. If separate heat exchangers are used, care must be taken to ensure that all heat exchangers are designed to provide primary return temperatures high enough to satisfy the minimum requirements of the primary distribution system.

There could be some advantage in connecting loops with different temperature requirements (as indicated in Table 3.1) in series rather than in parallel, which is most common in HVAC system design. The benefit of "cascading" the different loops is to increase the mixed return temperature (and the ΔT), and consequently reduce the overall flow requirements, both in the primary (district cooling system) and in the secondary (customer system). As an example, the chilled water for a refrigeration condensing loop, with chilled water temperature requirements of 13°C or higher, could be connected in series with a AHU coil loop, which normally returns water at 12°C or lower. Even if the cascading concept is viable in theory, it is often not practical to implement due to the secondary system configuration and cooling load requirements. The largest cooling load for most buildings is associated with cooling and dehumidifying of the supply air. The AHU equipment is typically located in numerous mechanical rooms, scattered throughout the building. In order to take advantage of the potential cascading, the other cooling systems', for example, refrigeration condensing, induction, etc., pumping equipment would have to be located in the same mechanical rooms as (or adjacent to) the AHU coil pumping equipment. Furthermore, the load and flow requirements for these systems (i.e. induction, etc) are typically significantly less than the AHU chilled water system. Thus, in reality, the cascading is normally limited to a selected few loops. One other limiting factor is the flow and ΔT considerations for the cascaded systems. It is generally desirable to operate the individual systems with as large a ΔT as possible to limit the flow requirements, and thus minimize the cost for the pumping, piping system, and terminal equipment heat transfer surfaces.

Temperature reset control, based on the outdoor temperature, should be utilized in the various sub-circuits in the secondary system. Balancing valves should be installed for each sub-circuit on the risers to balance the main secondary system.

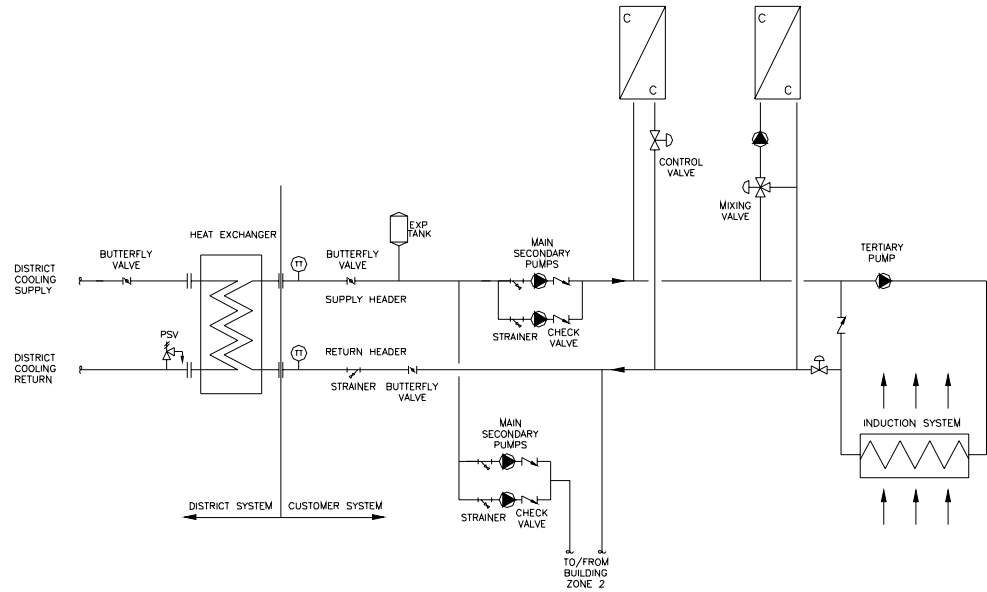

Part I Figure 5.10: Cooling system with multiple building zone pumps and sub-circuits

5.1.9 Building Secondary/Tertiary System Pumps

To maintain a high ΔT in the secondary system, it is imperative that the system is designed for variable flow. This means that only two-way or three-way mixing control valves must be used in the system. In order to fully utilize the potential operating savings, created by the variable flow demands in the system, a variable speed pumping system should be considered. Building cooling systems designed with two-way valve controls on the cooling elements work well with variable speed pumping systems.

Variable speed pumping may cost more initially, but it saves energy and wear on the mechanical system, in particular the control valves. As shown in Figure 5.11, the pump head at 50% flow conditions requires significantly lower head than the design (approximately 75% lower according to the Affinity Laws). Without variable speed, the control valves would have to dissipate this head difference (Delta H) to change the operating point. Not only does variable speed reduce this pump energy loss, it also tends to improve the controllability by allowing the valve to operate within its optimum control range, which again reduces the wear and tear on the control valves and actuators.

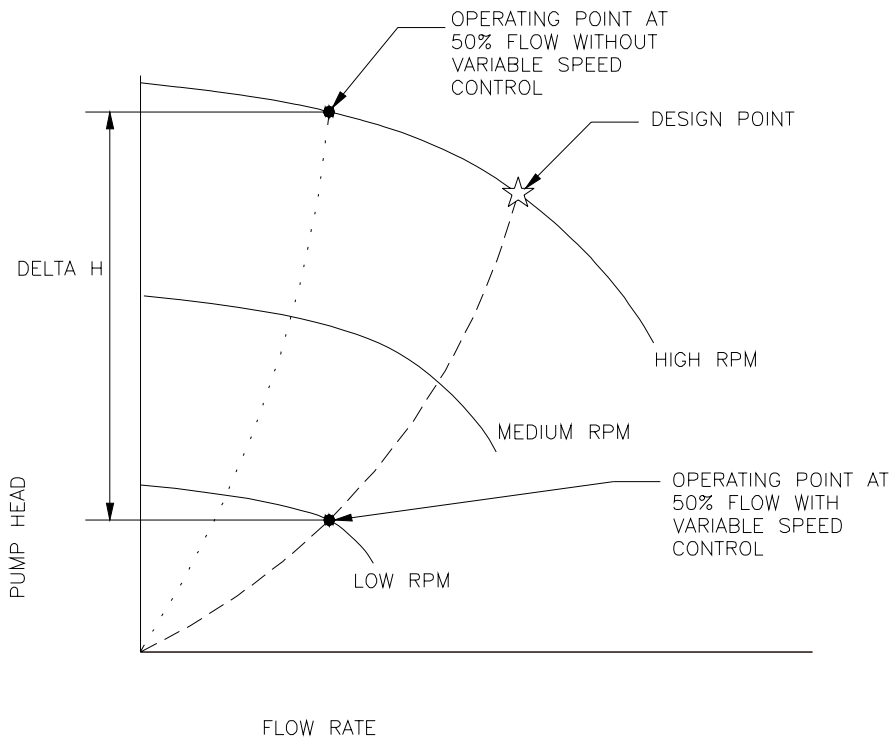

Part I Figure 5.11: Pump characteristics at 50% flow rate

5.1.10 Air Handling Units Coils and Other Terminal Equipment

As emphasized in Section 6, high return water temperature is an important design goal. Table 5.1 shows common design temperature objectives for existing (“conventional”) and new (“optimum”) building secondary systems, serving various types of cooling equipment.

Temperatures in a specific case will depend on the supply temperature of the district cooling system and other site-specific factors.

Part I Table 5.1: Common design temperature objectives

	Existing Buildings				New Buildings			
	Supply °C	°F	Return °C	°F	Supply °C	°F	Return °C	°F
AHU Coils	5.5-6.7*	42-44	11-12	52-54	3.3-4.4**	38-40	15.5	60
Radiant Panels	15-18	60-65	18-21	65-70	15-18	60-65	18-21	65-70
Fan Coils	5.5-6.7*	42-44	11-12	52-54	3.3-4.4**	38-40	15.5	60
Induction Units	13-15	55-60	18-21	65-70	13-15	55-60	18-21	55-70
Refrigeration Condenser	13-21	55-70	18-26	65-80	13-21	55-70	18-26	65-80

*Typical design temperatures commonly used for HVAC systems in North America.

**Minimum secondary supply temperature with an ice-based district cooling system.

The majority of cooling equipment used for cooling and dehumidification in HVAC systems incorporates air handling unit (AHU) coils or fan coil units (FCU). In North America, induction systems are also quite common in high-rise office buildings (perimeter system). Radiant panel cooling has traditionally not been used for cooling applications in North America (more commonly used for heating) since it is only suitable for sensible cooling (not latent or dehumidification). However, some applications, particular in drier climate zones, can be found, and the interest in the technology is on the rise due to the high thermal comfort and capital savings achievable with radiant cooling compared to traditional space-conditioning equipment.

Based on the above, a secondary return temperature of 12°C (54°F) can be achieved in existing buildings utilizing AHU cooling coils as the major cooling equipment. For new buildings, a brief review of the performance of standard AHU coils shows that the return can be increased to 15.5°C (60°F) by increasing the number of rows (from the “standard” 4-6 rows to 8 rows). Variable flow and/or scheduled water temperature in the secondary system is an important element in achieving high return temperatures.

The larger ΔT design will, however, require larger coils (increased heat transfer surface areas). The incremental cost for the larger surfaces will, normally, be offset by the smaller pipe sizes, valves, pumps, etc. as well as reduced pumping requirements. In fact, for systems with relatively extensive piping, the incremental cost for the extra coil surface could be offset by the smaller pipe sizes alone. It is important that the benefits, both to the district cooling system and the building owner, be identified to potential district cooling customers at the design stage of the building HVAC system.

To achieve the above return temperature at peak load conditions, as well as to maintain a high ΔT at partial load conditions, it is imperative that the system is designed for variable flow. The flow through the coils must be controlled by correctly sized, fully modulating two-way or three-way mixing control valves as shown in Figure 5.12.

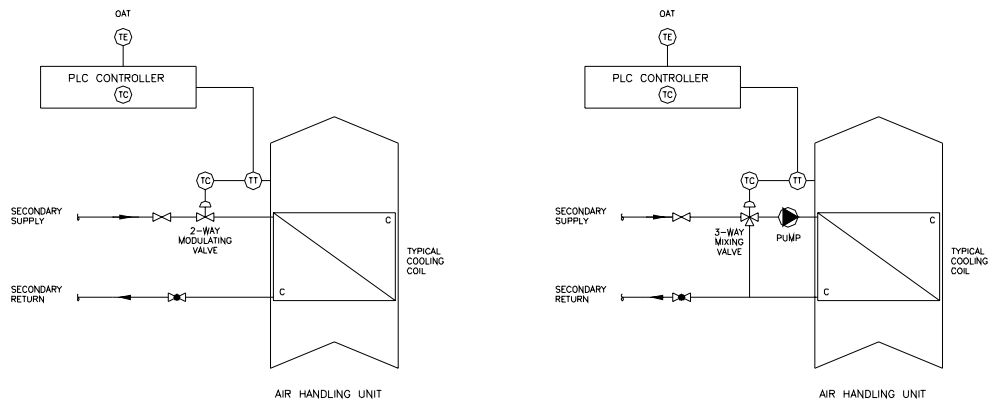

Part I Figure 5.12: Typical air-handling unit connection to secondary system

AHU coils are usually connected directly to the main secondary system. The control valve should be closed when the coil is not required for cooling. Design temperature objectives are suggested in Table 5.1.

Fan coil units should be equipped with automatic or solenoid shut-off valves if no other control valves are installed. Shut-off valves will prevent water from returning without being cooled if the fan is not running. A solenoid valve is normally connected to the fan contactor.

5.1.11 Water Treatment

In a closed water loop with minimal make-up water requirements, chemical water treatment is normally limited to neutralization of corrosive properties and control of scaling in heat exchangers. For open ice-based systems, additional oxygen scavenger and corrosion inhibitors may be required than in closed loop systems. For direct connected systems, all water treatment is normally provided at the central plant.

5.1.12 Expansion System

A water expansion system should be installed for every closed loop system. Any standard method, such as an enclosed pressure vessel, can be used. For direct connected systems, the water expansion and system pressurization will be handled from the central plant.

6 Building Conversion

Introduction

This chapter describes key points in the review of a building's suitability for conversion to district cooling, required modifications, and a brief discussion on the performance of terminal equipment (i.e. cooling coils) and its impact on the district cooling system performance.

The building conversion description in Section 6.3 through 6.6 will focus on larger buildings with centralized hydronic systems, and based on North American experience. Other cooling systems commonly used in residences and other small buildings i.e. single packaged A/C units, direct expansion (DX) units, etc. will only briefly be discussed in this report. The suitability and economics of converting these types of building categories to district cooling is generally not favourable.

Cooling Systems Types and Conversion Suitability

This section describes the different types of cooling systems used in commercial and public buildings in North America, and the conversion suitability of these systems. A building may utilize one or more of the following types of cooling systems:

6.1.1.1 Chilled Water Systems

- *Air Handling Unit Coils* – Chilled water is supplied to cooling coils in air handling units. These units are normally configured for air cooling and dehumidification.
- *Fan Coil Units* – Chilled water is supplied to coils in terminal equipment located in each cooling zone. These units could be configured for air cooling with or without dehumidification.
- *Induction Units* – Central conditioned primary air is supplied to the induction unit plenum. Medium/high velocity air flows through the induction nozzle and induces secondary air from the room through the secondary coil, which is supplied with chilled water from a central source. These units are configured for sensible air-cooling only.
- *Radiant Panels* - Chilled water is circulated through pipes embedded in the floor, walls or ceiling of the conditioned space. These units are configured for sensible air-cooling only. These chilled surfaces then cool the surrounding space by convection and radiation. Panels are described as radiant cooling panels if more than 50% of the heat transfer is by radiation. These panels can be integrated into either a 4-pipe or 2-pipe district energy system. Comfort levels can be well maintained by controlling the radiant heat transfer of each room.

6.1.1.2 Electric Systems

- *Unitary Split-System Unit* – A split system consists of an indoor (self-contained) unit with an electric-driven compressor system with air distribution and temperature control with either a water or air-cooled condenser.
- *Rooftop Units* – Packaged air handling units for outdoor applications, include unitary equipment ducted air distribution (for single or multi-zone applications) and temperature control. The compressor-driven direct expansion (DX) refrigeration systems utilize either reciprocating or electric-driven compressors. Units are often fitted with a direct or indirect gas-fired heating section.
- *Heat Pumps* – Tempered water is circulated to individual water-to-air heat pump units located throughout the conditioned space. The heat pumps can operate in either cooling or heating mode (i.e. rejects or extract heats to/from the hydronic loop) and provides year round heating and cooling.
- *Packaged A/C Units* - A fan unit with an electrical driven compressor refrigeration system is used to transfer heat from a space; the evaporator cools the space while the

condenser rejects heat to the outdoor air. These packaged units are completely self-contained.

Generally, chilled water systems are relatively easy to convert to district cooling. Conversions of electric systems are generally more difficult and costly. The relative suitability generally found for each cooling system type is summarized in Table 6.1. However, it is important to note that site-specific factors can result in differences from these generalizations for a specific building.

Part I Table 6.1: Conversion suitability of cooling system types

	Low	Medium	High
1. Chilled Water			
Air Handling Unit Coils			X
Fan Coil Units			X
Radiant Panel			X
Induction System			X
2. Electric Equipment			
Unitary Split-System	X		
Rooftop Units	X		
Heat Pumps		X	
Packaged A/C Units	X		

Section 6.3 presents a general procedure, **primarily for large buildings**, for conducting the conversion evaluation and design. Conversion of specific types of terminal cooling equipment and distribution systems within both the two major categories of building cooling systems are then discussed.

Procedure for Building Conversion

The following procedure describes the different steps that should normally be taken to assess and implement a building conversion.

- Building survey and schematic design.
- Building peak cooling load and annual energy requirements.
- Component compatibility.
- Conversion concept and cost estimates.
- System optimization and detailed design.
- Construction schedule.
- Installation, testing and commissioning.

6.1.2 Building Survey and Schematic Design

A complete survey of the cooling system should be made. The purpose of the building survey is to collect sufficient data to establish a technical concept and associated costs to convert the building from individual chiller operation to district cooling. The survey should establish how the building space is currently air-conditioned and the suitability for conversion to district energy. Generally, buildings with centralized chilled water systems are the most suitable for conversion as outlined in Table 6.1. Buildings with unitary electrical cooling equipment generally are not suitable for conversion to district cooling due to the very high conversion costs, which often do not warrant any further assessment of these buildings.

Another important part of the building survey is to gather sufficient data and information to determine the buildings' thermal peak loads and energy requirements. This type of information and data entails annual gas and power consumption, chiller logs, chiller installed capacities, operational experience as well as information on building square footage, building category (office, hotel, etc.), and operational schedules. Operating personnel should be interviewed to

assess the equipment and system operation. Building operating engineers can provide valuable information regarding the history of the equipment and all space conditions, such as the proper amount of ventilation and proper cooling distribution.

Locations of existing major equipment, for example, chillers and pumps, must be established to determine a suitable location for the energy transfer station, and the routing of the district energy service piping. A review of the existing HVAC system configuration and controls should be conducted to establish if any modifications are required to the existing system. Engineering drawings and specifications are very helpful in tracking down mechanical equipment and system configuration in a large complex. However, existing drawings should not be completely relied upon. In many cases, alterations to the initial design of a system limits the usefulness of the original documents.

Unitary equipment (i.e. computer room cooling, rooftop units, etc), not connected to the central system, must be identified since these types of systems are often not suitable for conversion. This would have to be factored into the building's estimated thermal peak load and energy requirements.

A schematic diagram of the existing system will help in defining the scope of work. Sketches of the building cooling system piping help to focus the engineer's attention on each system component.

6.1.3 Building Peak Cooling Load and Energy Requirements

A building's peak load is a very important calculation. The district cooling system has to be designed to provide enough capacity to deliver each building's peak thermal needs during peak days. If the system is under-designed, the customer will not be happy with the system, as the building's occupants will obviously be uncomfortable during peak weather periods. If the system is over-designed, then the capital costs to deliver the cooling will be too high and could affect the economics of the entire project.

The building's energy consumption must be determined, based on historical usage. In estimating future cooling requirements, it is important to take into account the energy conservation impact of the conversion to chilled water district cooling. To establish an accurate estimate of each building's peak capacity requirements, three different methods can be used. Obviously, the more information that is available regarding each building's systems, the more accurately its peak requirements can be calculated. The three ways to calculate peak capacity are:

- Use a watts per square meter estimate based on climatic conditions and building type.
- Determine a building's current installed chiller capacity and how much of it is utilized during peak conditions.
- Utilize existing electrical and gas load data in combination with degree-day data and a utilization factor.

Peak load must be estimated in order to size the heat exchanger and other components. The heat exchanger should not be sized based on nameplate capacities of existing chillers or other equipment, because this equipment may be oversized and implementation of energy conservation often accentuates this factor. Oversized equipment is costly in terms of the initial purchase cost as well as ongoing maintenance, and generally does not provide good controllability.

Electrical use data must be adjusted by a seasonal chiller efficiency factor. Chiller seasonal efficiencies (or Coefficient of Performance) range typically from 2.5 to 4.0.

The projected annual energy consumption should then be divided by a "utilization hours" factor to derive a peak load. Utilization hours is a factor which relates the peak energy requirement to annual usage for a given building usage pattern and climate.

6.1.4 Component Compatibility

The age, condition and cooling source of each component of the existing system must be assessed. The design supply and return temperatures of existing heat transfer equipment in a chilled water cooling system must be checked for compatibility with district cooling. The secondary system

must be designed to optimize the size of the new components to provide a high chilled water return temperature. Equipment can often be used as is or be modified quite easily to meet requirements.

6.1.5 Conversion Concept and Costs

The proposed conversion concept, designed to meet the specific needs of the building occupancy, is then established. The conversion should be as cost-effective as possible while meeting performance requirements. Reuse of existing equipment is an important element in keeping costs low. Conversion costs should be estimated to include the energy transfer station including associated service piping, building system modifications, removal of existing equipment, asbestos abatement, engineering, and construction management and commissioning support. A cost comparison between district cooling and on-site cooling should then be presented to the customer, normally in the form of a proposal. The cost-benefit analysis should include all costs associated with on-site cooling, both capital and operating costs.

6.1.6 System Optimization and Detailed Design

Based on the above steps, a decision can be made to proceed with detailed design and construction documents. The detailed conversion design should optimize the cost-effectiveness of the system without sacrificing the comfort of the occupants. System efficiency, equipment service life and maintenance requirements should all be considered.

Selection of the cooling elements in the air-handling units is critical for ensuring a large temperature drop, low air pressure drop and low water flow within the design limitations. In preparation of the documents, engineers should make sure that existing equipment and piping is isolated from new equipment for proper testing and cleaning.

6.1.7 Construction Schedule

When a building is being renovated for new occupancy, the construction schedule is generally easy to formulate. However, a more complex construction schedule is required for a building that will be occupied during the cooling system conversion. Residential high-rises, hotels, and industrial plants with process loads require precise construction schedules.

Planning, construction documents and bidding for an occupied building should be in place about three months before actual construction begins. The schedule will depend on the size and complexity of the project, equipment deliveries, and work force.

6.1.8 Testing and Commissioning

Proper testing, balancing, and adjustment are imperative for energy efficiency. Equipment should be tested to determine if it meets the design specifications. Experienced and qualified personnel should implement testing, balancing, and adjustment with central calibration. The organization that will test and calibrate the equipment should be independent from the installation contractor and should preferably be hired directly by the building owner.

If new larger chilled water cooling coils (with additional rows) are installed in existing air handling units, the air pressure drop could be higher than with the original coil configuration. Therefore, fan adjustments are necessary to deliver the proper air volume and temperature.

It is important to install adequate test ports in piping at each cooling coil for inserting pressure and temperature sensors for balancing the hydronic system. Proper balancing is extremely important for energy conservation as well as to ensure comfort and minimize operating costs.

Control systems can often be kept in their original configuration, but control valves may have to be changed. It may be advantageous to upgrade control systems for additional energy conservation.

Low ΔT Discussion

6.1.9 General

As per the previous discussion, optimization of the system ΔT is critical for the successful operation of a district cooling system. The customer ΔT must be able to comply with the design parameters of the system. Failure to meet the design ΔT requirements could affect both the customer and district cooling system capacity and efficiency. The low ΔT problem should always be part of the building conversion evaluation. It is generally not advisable to determine the secondary system ΔT based strictly on design specifications. Information on the actual operating ΔT conditions is critical. Therefore, information provided by building operators and/or retrieved from chiller logbooks are important sources in this regard.

6.1.10 Low ΔT Causes and Mitigation

The performance (or lack of) of the existing cooling coils and control valves creates the low ΔT problem. The following are some of the causes of, and mitigation steps for, the low ΔT problem.

Improper Set point (or Poor Controls Calibration) - This problem is created when the supply air set point is lowered from the design set point, often in response to complaints from occupants in the building. The cooling valve will open to increase the flow rate through the coil, which again will lead to a corresponding decrease in ΔT . The effect of this is illustrated in Figure 6.1. As can be seen from this curve, a modest drop in the supply air set point from 13.3°C to 12.8°C can cause a 50% increase in the coil flow rate and ΔT to drop by 30%. In fact, a lowering of only a few degrees to the air supply temperature may cause operating conditions, which no flow can ever satisfy (even with the control valve 100% open). This is likely the greatest single cause of the low ΔT syndrome.

Mitigation – Check set points and recalibrate controls regularly. In some cases, the set point changes may be permanent due to an increased cooling load in the space served by the air handling unit. In this case, the corrective action may include a complete coil change.

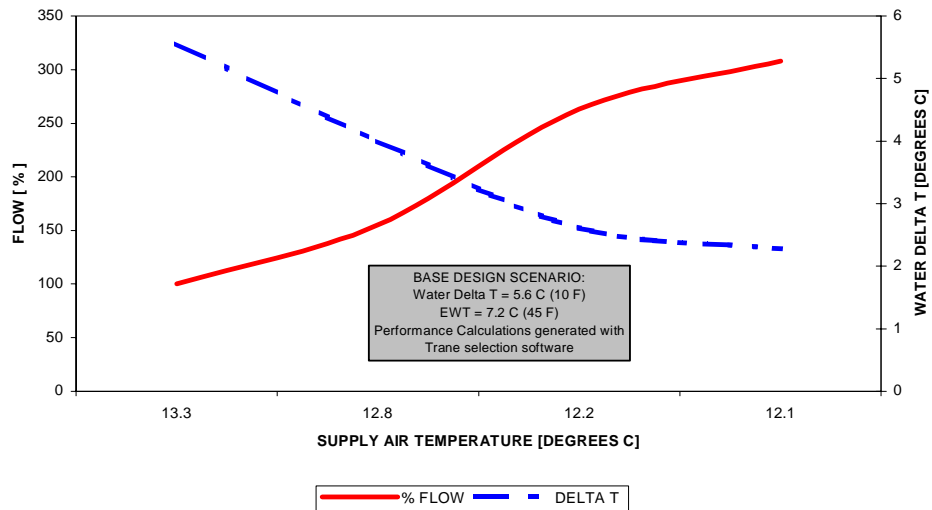

Part I Figure 6.1: Generic coil performance for varying supply air temperature

Three-way Control Valves or Improperly Sized (or worn) Two-way Valves – Three-way (diverting) valves, by their nature, bypass supply water into the return to control temperatures at the load. These systems operate with virtually constant flow, which is detrimental to the system ΔT . Likewise, oversized or worn (i.e. "wire drawn") two-way valves may act as three-way valves which can lead to "hunting". This means that the valves alternately open and close, causing over- and under-shooting of the set point. This results in very unstable operation. Another problem could be undersized actuators with an insufficient close-off pressure rating which can cause the valve to open when that is not intended.

Mitigation – All three-way (diverting) valves must be replaced by properly sized two-way, fully modulating valves to achieve variable flow conditions. Plugging the bypass port does not usually offer a good engineering solution since the three-way valve actuator spring range ratings are not

adequate to close against the system pressure. In addition, the existing valves may be oversized which can cause unstable operation (“hunting”).

Reduced Coil Effectiveness – Coil heat transfer effectiveness is reduced by waterside fouling (i.e., slime, scale or corrosion on the inside of the coil tubes) and airside fouling (i.e., dirt build-up). Any reduction in coil effectiveness increases the flow rate of water required to deliver the desired leaving water temperature, thus reducing ΔT .

Mitigation – Waterside fouling is easily controlled by proper water treatment. Since the chilled water piping is most often a closed system, water treatment need not be an ongoing expense. Reduced airside fouling is a very good reason to consider increasing the filter efficiencies.

Chilled Water Systems

6.1.11 Chilled Water Distribution

Central chilled water systems are configured as closed loop systems, utilizing pumps to provide circulation. The pumping configuration could be configured with or without primary chiller pumps, for example, direct primary or primary/secondary pumping configuration. The piping configurations are either:

Direct return: A circulation system routes water back to the primary heat exchanger via the shortest path from each appliance.

Reverse return: A circulation system uses a return piping path from each appliance such that all circuits are of equal pipe length, i.e. self-balancing.

Conventional chilled water systems can use district cooling with few changes. However, such systems should be evaluated for suitable temperature drop.

Existing terminal units should be investigated for impact of changing water temperatures and flows. The chilled water flow in the customer’s side must be variable flow to be varied based on the load swings, preferably with variable speed pumping. The terminal units, within the building, connected to the customer’s chilled water loop (i.e. air handling units, fan coils, etc.), may require modifications and therefore operate with variable water flow (two-way control valves, etc.). This ensures maximum return water temperatures.

Existing coil rows, fin spacing, tube velocity, and circuiting should be investigated to determine any impact (potential reduction of capacity) to the existing HVAC system. Besides removing three-way control valves, the most effective method of increasing the leaving water temperature (LWT) of a cooling coil is to lower its entering water temperature (EWT). This effect is illustrated in Figure 6.2. As can be seen in this figure, if the EWT to the coil is lowered from the 5.6°C (42°F) original design to 3.3°C (38°F), the ΔT should increase from 5.6°C (10°F) to 8°C with virtually no impact on the coil capacity.

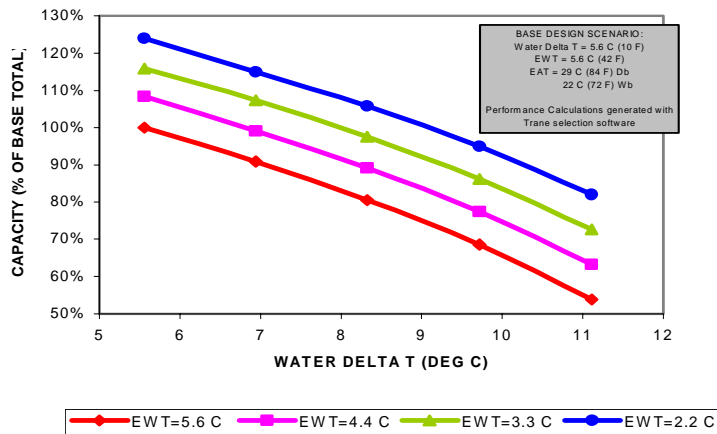

Part I Figure 6.2: AHU coil performance for variable flow and supply air temperatures

The building's secondary water systems will experience some additional pressure drop through the building interface (heat exchangers and piping). In particular, buildings with penthouse chiller room locations may require extensive interconnecting piping and thereby higher system resistance. A potential for an increased system ΔT , with district cooling, due to a possible lower supply temperature (in particular with ice based system), and the resulting reduced flow requirements may compensate for the increased system resistance (lower flow rate would move the system operating point higher up on the pump curve). This will have to be determined for each building individually, at the design stage.

6.1.12 Radiant Panel or Induction Systems

Normally, existing radiant panel systems are compatible with district cooling. The temperature requirements are normally 15°C or higher, for example, temperature should be maintained at least 0.5°C higher than the room design dew-point temperature to prevent condensation on the room side of the panels. In fact, there is a potential to connect the radiant panel system in series (cascade connection) with the chilled water loop serving air handling units cooling coils since the return temperature from the coils would be suitable for the panel loops.

Two-way control valves typically control the panel elements. In some cases, three-way valves may be used. Even with three-way valves, modifications to the controls would typically not be required due to the high temperature requirements of panel cooling systems.

6.1.13 Induction Systems

Induction system temperature requirements are very similar to that of the radiant panels, and normally require no modifications to be compatible with district cooling.

6.1.14 Air Handling Systems

Temperature requirements must be checked, but normally there will be no problem in connecting cooling coils and other existing chilled water elements in the air handling systems. As noted above, if a three-way valve controls an element, the valve must be replaced by two-way modulating valves to provide variable system flow. Valve size must be checked for adequate pressure drop compared to system design.

Furthermore, the performance of the existing coil must be reviewed, and a coil replacement may be required to meet the ΔT requirements of the district cooling system.

6.1.15 Fan Coil Units

Again, temperature requirements must be checked, but normally there will be no problem in connecting a fan coil unit. An automatic shut-off valve (i.e., solenoid valve) should be installed in the chilled water supply to only allow water flow through the coil when the fan is on.

Electrical Systems

6.1.16 Rooftop Units

Package air handling units, air make-up units, or blow-through units are used to cool make-up air in warehouses, shop areas, etc. They can be factory-assembled or site-assembled, and have a blower, direct expansion (DX) refrigeration unit, filter and fresh air and return air damper sections. They can have extensive ductwork for air distribution or they can be roof-mounted with air discharge directly into the room below or through a short duct.

These types of systems are generally not good candidates for conversion due to the very high retrofit cost. It is, however, technically feasible, and a conversion would entail replacing the DX system with a chilled water coil and installing a centralized chilled water piping system. When selecting the chilled water cooling coil, the air pressure drop should be minimized. Air handling units are normally selected with minimal air resistance. Coils with a large air pressure drop might require replacement of the motor pulleys and sheaves to handle the additional pressure drop.

Freeze protection would have to be provided at the unit or alternatively the chilled water loop would have to be drained down in the winter.

6.1.17 Heat Pumps

Unitary water-to-air heat pumps connected to a recirculating water loop are most commonly used in large office complexes with large interior spaces. The system provides decentralized, year-round heating and cooling by continuously circulating non-refrigerated water throughout the building.

The water temperature is maintained throughout the year in an approximate range between 18°C (65°F) and 35°C (95°F). At the low end of this range, additional heat is needed from a supplemental heat source such as a heat exchanger, electric boiler or fossil fuel boiler. During the cooling season, heat is dissipated from the unit into the circulated loop and rejected to the outdoors through a cooling tower.

These types of systems are not suitable for a conversion to district cooling. The only (realistic) potential is to provide chilled water for heat rejection (condensing) purposes, which would eliminate the need of the cooling tower. A full conversion to district cooling would require very extensive retrofits, including replacing all the heat pumps with fan coils and installation of a new two-pipe system for chilled water distribution.

6.1.18 Packaged A/C Units

These types of units cannot be converted and must be replaced with hydronic units (i.e. fan coil units) connected to a new centralized chilled water distribution system.

Other Considerations

6.1.19 Recapturing of Space

District cooling equipment requires much less space than chillers and associated equipment. Consequently, space can often be recaptured for other useful purposes. This should be taken into consideration in the layout of the new installation.

6.1.20 Staffing and Management

The equipment in the building energy transfer station requires minimal staff attention for operation and maintenance. The regular building maintenance personnel can monitor all equipment except the meter, which is usually maintained by the utility. There is no practical need or regulatory requirement for full or partial attendance by licensed operators, as would be the case with chiller operation. Compared to chiller operation, district cooling will save labor and maintenance costs, and there is a potential for additional savings in administrative and insurance costs.

A schedule for preventive maintenance of the equipment in the energy transfer station should be developed based on manufacturers' recommendations. Good records on consumption, temperatures and pressures are helpful tools in a preventive maintenance program.

7 Appendix: Case Histories – Conversion to District Cooling

Case History 1 - BNC AMERICANA Building, Houston, Texas, USA

7.1.1 Existing Cooling System

The BNC Americana Building is located at 811 Dallas Street in Houston, Texas. The 185,000-ft² (17,200 m²) commercial office building was built in 1961 on top of a five story parking structure.

Part I Figure 7.1: Exterior view of Americana building

There are 10 floors of office space above the garage and one level below the garage for multipurpose use. The general building hours of operation are 5:00 am to 6:00 pm weekdays and 5:00 am to 2:00 pm Saturdays. There are data centers or 24-hour loads in the building at this time. The original central plant was located on the 15th floor of the office building. There were two 340 Ton (1196 kW) Refrigeration (TR) Trane centrifugal chillers piped in series. Both chillers utilized R-11 refrigerant and were original to the building. A dual cell Marley cooling tower installed in 1992 was located on the roof of the central plant. From discussions with the building's operational staff, we estimated that two chillers at 75% load were required to meet the peak summer day cooling requirement with the building at 90% occupancy.



The building's chilled water distribution system was designed around constant speed primary pumping system with all water distributed to a large field erected custom air handling unit (AHU) and a smaller outside air handling unit (OAHU), both located adjacent to the chiller room. The original chilled water air handling unit coil was designed at Entering Water Temperature (EWT) of 44°F (6.7°C) and Leaving Water Temperature (LWT) of 54°F (12.2°C) conditions. The large AHU has a dual duct configuration (both hot deck and cold deck ductwork are distributed from the same unit) and is routed through a singular vertical shaft adjacent to a stairwell. The smaller OAHU had a three-way control valve; however, the larger AHU did not have a control valve. The original AHU supply air temperatures were controlled by adjusting the leaving chilled water set point by energizing a number of chillers.

7.1.2 Conversion

After successfully negotiating a 20 year chilled water delivery agreement, we analyzed numerous service alternatives to the building. Due to the height of the building and the static pressure available from the district cooling distribution system pumps, it was advisable to find a location for the plate and frame heat exchanger as low as possible. The Energy Transfer Station (ETS) was located on the street level of the parking garage in a 22 feet long by 10 feet wide by 10 feet high existing storage space located at the parking garage entrance.

Part I Figure 7.2: ETS location before installation



The area located directly below this location was a tenant print shop. The district cooling service lines were routed in the ceiling cavity of the print shop and through the floor of the garage to the heat exchanger. An ETS room was constructed to enclose the heat exchanger and protect it from the ambient conditions.

Part I Figure 7.3: ETS after installation

Since the building's chilled water distribution system was confined to the 15th floor, we installed customer connecting piping from the heat exchanger to the customer chilled water loop on the 15th floor. From the ETS room on the street level, the connecting piping was routed through an opening in the center portion of the ramp of the parking garage. Once the piping was at the underside of the 6th floor office level, it was offset laterally and entered the building in the janitor's closet adjacent to the stairwell. Since these janitor's closets were stacked above each other, we core drilled each floor and routed the connecting piping up to the ceiling cavity of the 15th floor. The piping was routed to the 15th floor mechanical room and connected to the existing chilled water header and a new building chilled water circulation pump.



The customer's original design was to install a new central plant, which was estimated to be over \$560,000. The building owner also avoided additional maintenance, operation, water, chemical, insurance, refrigerant and electricity costs.

7.1.3 Recommended Cooling Equipment

The original load estimate for the building was 500 TR (1758 kW); however, the building owner performed multiple energy retrofit projects to decrease the building load requirements to 450 TR (1583kW). A single 450 TR (1583 kW) heat exchanger was installed with future frame capacity to accommodate 600 TR (2110 kW). The following table represents the heat selected for the building connection:

Part I Table 7.1: Heat exchanger selection for BNC Americana

HX Type	Qty	Load TR (kW)	Cold Side Conditions				Warm Side Conditions			
			Flow GPM (L/s)	EWT °F (°C)	LWT °F (°C)	Delta P psig (kPa)	Flow GPM (L/s)	EWT °F (°C)	LWT °F (°C)	Delta P psig (kPa)
ALFA LAVAL	1	400 (1407)	533 (33.6)	34 (1.1)	52 (11.1)	6.38 (44)	685 (43.2)	54 (12.2)	40 (4.4)	9.93 (68.5)

The heat exchanger is de-rated by approximately 10% of the building total load in order to enhance part load performance for the heat exchanger.

One of the energy projects mentioned above, was converting the existing air distribution equipment to a Variable Air Volume (VAV) system. The building owner installed a large Variable Speed Drive (VSD) on the AHU fan motor allowing the chilled water coil to be re-selected for lower entering water conditions, thus lowering the cold deck leaving air temperature and reducing the required volume of air to cool the building. The lower temperature water also allowed us to install a 40 Horsepower (HP) (30 kW) chilled water pump, which was smaller than the original 60 HP (45 kW) chilled water pump. In addition, a chilled water control valve was installed to optimize temperature control and maximize the return water temperature. Both the new chilled water pump and control valve were linked to the new building automation system the building owner installed.

7.1.4 Conversion Costs – (2001\$)

The following table summarizes the cost of converting the existing building to the district cooling system:

Part I Table 7.2: Conversion cost estimate

ITEM	COST (US \$)
Heat Exchanger with Shroud and Accessories	\$ 16,650
Heat Exchanger and Controls Installation, Piping, and Wiring	\$ 73,500
ETS Controls (Flowmeter, Temperature Sensors, PLC)	\$ 15,845
ETS Room (Walls, Door, Fan, Lighting)	\$ 10,400
Janitors Closet Ceiling Restoration and Core Drill Clean-up	\$ 5,854
Fiber Optic Cable Link Up	\$ 3,775
Cathodic Flange Isolation Kit	\$ 500
Customer Connecting Piping and Valves	\$ 92,583
New Building Circulation Pump	\$ 6,488
VSD for Pump plus Electrical	\$ 9,180
AHU Control Valve	\$ 2,785
Print Shop Ceiling Repair Work and Carpet Repair	\$ 1,500
TOTAL COST	\$ 239,058

7.1.5 Results

After one year of operation, the estimated savings experienced by the building owner is approximately \$84,000. The following analysis summarizes the cost savings breakdown for the building self-cool option versus the district cooling option:

Part I Table 7.3: Saving analysis summary

One Year Service on Northwind System:	AMERICANA
Peak Tons (Contracted)	450
Estimated EFLH	2,459
Total Actual Ton Hours (MWh)	646,204 (2,273)
Self-Cooling Costs: (One Year Service)	
Electricity	\$ 73,147
Water/Chemical	\$ 14,490
Maintenance	\$ 27,000
Insurance	\$ 2,040
Refrigerant	\$ 288
Operation	\$ 23,660
Proposed Base Capital	\$ 560,000
Annual P/I (@9.5%, 20 years)	\$ 31,776
Total (To-Date) Self-Cooling Costs	\$ 172,401
Blended Self-Cooling (\$/ton)	\$ 0.27
Northwind Cooling Costs:	
Capacity Charge (Actual)	\$ 21,342
Consumption Charge (Actual)	\$ 71,955
Electricity	\$ 6,522
Low Temperature Air Side Savings	\$ (11,472)
Total Annual Northwind Cooling Costs	\$ 88,346
Blended Northwind Cooling (\$/ton)	\$ 0.14
TOTAL ANNUAL SAVINGS	\$ 84, 054

Note the consumption rate for the building is less than estimated since the building is currently not fully occupied due to building renovation projects.

Case History 2 – Kv. Grävlingen (an office and retail building), Stockholm, Sweden

7.1.6 Summary

This Case Study discusses the cooling system conversion of Kv. Grävlingen, an office and retail building in Stockholm, Sweden, from cooling with its own chillers to connecting to a district cooling system. It was one of the first buildings to be connected to the district cooling system in 1994. It was built between 1974 and 1975 with a cooled area of 27,000 m² (290,000 ft²). The building varies in height between 6 and 10 floors above ground level and has 3 floors below ground level.

The building was first directly connected but was remodeled in 1999 to be indirectly connected. The main reason for this change was the expansion of the district cooling system and the necessary upgrade of the system's pressure rating from 6 bars (87 psi) to 10 bars (145 psi) while the building's internal cooling system was only rated for 6 bars.

The project included these activities:

- Demolition of existing chillers (2) and cooling towers.
- Provision and installation of all necessary interconnecting piping between the district cooling and the building's cooling system.
- Replacement of all control valves to convert the system to a variable flow system.

When first operating the system, there were some problems controlling the chilled water supply and return temperatures. The system was difficult to control because of its long response time. With too low of a return temperature from the customer (secondary side) system, the original control sequence shifted to controlling the return temperature according to the set minimum return temperature. Reprogramming the control sequence to reset the supply temperature, based on the return temperature deviation from the return temperature limit, solved this problem.

7.1.7 General

Converting a building from a cooling system using its own chillers to a district cooling system is similar to connecting a building to a district heating system. Both original systems have their own production units and a constant flow system. During conversion, it is very important to eliminate all three-way valves that are common in constant flow systems, as they return unused energy back to the chillers, which is not preferable for a district cooling system. By eliminating all the three-way valves, the system will become a variable flow system.

7.1.8 Building Cooling System Description Prior to Conversion

The building produced chilled water with electrical centrifugal chillers and the condenser water was cooled with cooling towers located on the roof.

- The system utilized a supply temperature of 6°C (43°F) and a return temperature of 12°C (54°F).
- The total chiller capacity was 1200 kW (≈340 tons), split up between two electrical centrifugal chillers of 600 kW (≈170 tons) each.

The building's cooling demand was established from tenant space and process loads. Calculations indicated that the peak cooling load was the same as the original installed chiller capacity.

When calculating the cooling load, normally factors like transmission heat gains, solar radiation, building's thermal inertia, people and internal loads are taken into consideration. In addition, the latent cooling load for dehumidification at the cooling coils was important to consider in this case.

The building was only cooled by air through air-handling units. Three-way diverting valves were controlling the chilled water flow at each air-handling unit to maintain a specified minimum flow

through the chillers. The pumping configuration was direct primary with no secondary pumps for each air-handling coil.

The building was converted to district cooling because the existing equipment was at the end of its economical lifecycle (20 years old) and the alternatives were either to replace the existing equipment or convert to district cooling.

7.1.9 Building Cooling System Description After Conversion

The building was at first directly connected to the district cooling system, without a heat exchanger.

7.1.9.1 Conversion Budget

The conversion did not exceed the budget cost that was made in 1994. The budget cost was calculated to be 300,000 SEK (US\$30,000 with an exchange rate of 1 US\$=10 SEK), and included the following:

- Demolition of existing chillers (2) and cooling towers.
- Provision and installation of all necessary interconnecting piping between the district cooling and the building's cooling system.
- Replacement of all control valves to convert the system to a variable flow system.

7.1.9.2 Secondary System Modifications

The conversion required the building's supply temperature to be changed to match the district cooling system supply. As well, the return temperature had to be adjusted to meet the district cooling requirements. The new supply and return temperatures for the building were 7°C and 16°C (45°F and 61°F), respectively. The higher differential temperature reduced the capacity of the air-handling units by approximately 15%. The air-handling units could therefore only deliver 1000 kW instead of 1200 kW after the conversion.

The capacity reduction resulted from the decrease in heat transfer from the air to the water in the coils due to the reduction in flow. During the summer season, exhaust air was mixed with the fresh air supply to compensate for the loss in capacity. By mixing the cooler exhaust air with the fresh air, the supply temperature of the air was lowered. By mixing, the cooling system became more efficient and the existing coils could be kept.

Minor building modifications had to be made to convert the building. The piping system had the required 6 bar pressure rating. The majority of the modifications were to change the three-way valves at the air-handling units to two-way valves and to build the energy transfer station in the existing chiller room.

7.1.9.3 Start-Up, Operating And Maintenance

At the time of start-up, the following problems appeared:

- One strainer had to be replaced.
- Because of the height of the building compared to other connected buildings, air problems developed at the air-handling units.
- Coil leakages appeared. The leakages developed between copper and steel pipes. Two coils had to be replaced.
- Flow balancing problems.

During operation, there were problems controlling the chilled water supply and return temperatures. With too low of a return temperature from the customer (secondary side) system, the original control sequence shifted to controlling the return temperature according to the set minimum return temperature. The water had to circulate through the whole system before the new return temperature reached the sensor, making the system very difficult to control because of the

long response time. Reprogramming the control sequence to reset the supply temperature, based on the return temperature deviation, from the return temperature limit solved this problem.

Another problem that appeared during operation was the manual air bleed vents. They were installed at the return side of the cooling coils adjacent to the control valves. At low building cooling demand (with control valves almost closed), the pressure on the suction side of the valve became lower than the ambient pressure, resulting in air being sucked into the system when staff was trying to bleed air from the system. Keeping the control valves fully open when the system was vented solved this problem.

7.1.10 Further Changes To The Building

During 1995, new office spaces (that had not been cooled before) were equipped with air conditioning by radiant ceiling panels. Some benefits of these panels are that the cooling load of the air system is greatly reduced, thereby decreasing duct sizes and setting air requirements based only on the ventilation needs of the building.

The additional cooling load was indirectly connected, with heat exchangers, to the Energy Transfer Station (ETS). During 1999, the whole ETS was rebuilt to be indirectly connected.

The main reason for the ETS change to an indirect connection was the expansion of the district cooling system and the upgrading of the pressure rating from 6 bars (87 psi) to 10 bars (145 psi). Another advantage from the change was the distinct boundary between client and owner.

Part I Figure 7.4: Kv. Grävlingen building ETS and secondary system flow schematic

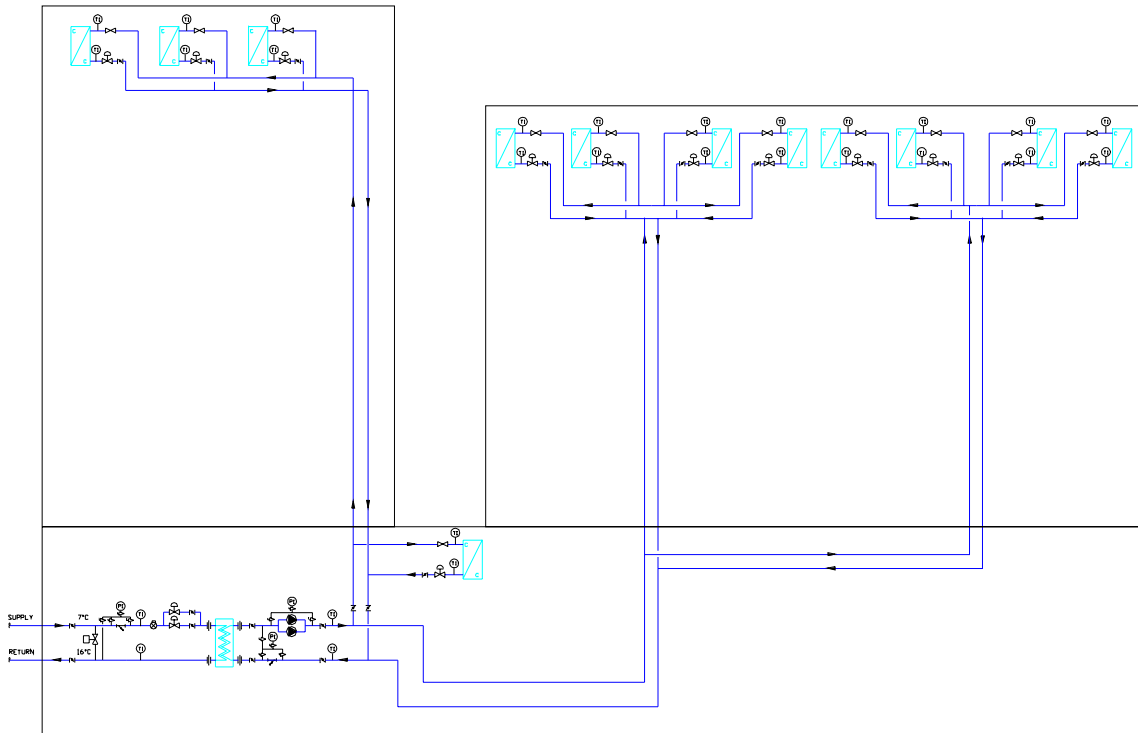

Part II: Heating Section

By
P. Milenstein
Onyx Group

8 INTRODUCTION

This part of the guide is intended to assist engineers and contractors in designing and implementing conversions of buildings to hot water district heating (DH), i.e. the circulation of hot water in a double pipe-network within a district or a complete city. The guidelines are applicable to a variety of building types, including domestic, commercial, retail, institutional and industrial. To some extent, it also covers the modernization of existing substations in order to improve overall conditions of operation.

The purpose is to provide practical advice on converting buildings in the most cost-effective manner, while ensuring that the system is technically sound and provides reliable and efficient heating system using DH hot water. This part of the report is based on the author's experience in designing and converting building systems and operating these systems with DH hot water.

As it is assumed that the user of these guidelines is an experienced heating, ventilation and air conditioning engineer or contractor, this report does not address the general aspects of building system design and installation.

This guide is not intended to supersede any guidelines or requirements set by the DH operator. In all instances, the engineer should always consult the DH operator.

9 EXISTING INSTALLATIONS

Introduction

This section reviews the different types of installations found in buildings that have the potential for conversion to district heating (DH). It is assumed that the reader will be conversant with the different types of systems that are prevalent.

In most instances, DH systems are built as indirect systems, i.e., the internal hydronic heating system is hydraulically separated from the DH system by means of a heat exchanger. In such systems, no large alterations are required during the installation, as the boiler is simply being exchanged by the heat exchanger.

In some places, direct connection may be possible and beneficial. Such systems allow the DH water to circulate directly into the house installation. This concept is often used in rather flat cities with low static pressures in the DH system. In this way, no loss of temperature through heat exchangers has to be taken in account. Normally, the differential pressure of the DH system is sufficient to circulate the water in the radiator system, whereby a local pump is also avoided. In this case, it is necessary that the radiator system be designed to withstand the maximum pressure of the DH system.

Design Principles – Hydronic Heating

9.1.1 Pressure Regimes

The pressure of a central heating system is normally dictated by the height of a building. However, heat emitters generally have pressure limitations. Radiators are typically built to working pressures of 6 bar, with some even less, especially older radiators. Other heat emitters such as coils for convectors and air handling units are often made to suit the process requirements.

9.1.2 Temperature Regimes

Hydronic heating systems in buildings are designed according to national codes and principles. These codes and principles generally vary from country to country. Table 9.1 provides examples of the design parameters applied, by some countries, for the design of central heating installations.

Part II Table 9.1: Examples of temperatures used for the design of central heating systems

Country	Supply Temperature	Return Temperature	Hot Water
Denmark	70	40	<60
Finland	70	40	55
Korea	70	50	55
Romania	95	75	
Russia	95	75	50
United Kingdom	82	70	65
Poland	85	71	55
Germany	80	60	55

Obviously, the layout of DH systems have to fulfill these conditions as a starting point. Nevertheless, it is a fact that many DH systems, over time, have achieved more efficient conditions. Examples of these are operation at reduced supply temperatures and/or better differential temperature of the system than originally planned. Improvement of insulation, introduction of double glazing and the installation of better control equipment are examples typically being introduced during the lifetime of a building, which allows for lower heating supply temperatures.

Experience has shown that many central heating systems, even from the beginning, are oversized, which means that the system is able to provide better cooling of the water than planned. For example, Danish radiator systems, for many years, were designed for $t_f/t_r = 90/70^\circ$. However, the operating temperatures of the DH system were typically 80/40°C and in recent years, even lower temperatures have been introduced.

System Suitability

9.1.3 Two-pipe Radiator Systems

These systems are readily suitable for conversion to DH systems. There are little or no modifications required and the heat exchanger can directly replace the boiler. Consideration need only be given to the radiator sizes if low return water temperatures have to be achieved.

As the circulating pumps are designed for the pressure loss across conventional boiler plant, and the heat exchanger is designed with a lower pressure drop, existing pumps do not need replacement.

Re-commissioning does not normally need to be carried out, unless a direct connection is chosen.

9.1.4 Single-pipe Radiator Systems

Single-pipe radiator systems, like two-pipe systems, can be readily converted to DH. The radiators on a single-pipe system will have been designed to ensure heat output at successive lower supply water temperatures. A low return water temperature will be extremely difficult to achieve. This type of system, therefore, appears to be problematic for a rational operation of a DH-system. Conversion into a double-pipe system should be considered from case to case.

Pumping will, again, not normally be affected as will the need for re-commissioning, unless the system is being improved in some way or another.

9.1.5 Convector and Air Handling Unit (AHU) Heating

Convectors and AHU coils would normally be heated from a separate constant temperature circuit. These systems would therefore be ideal for DH systems, with little or no modification required.

9.1.6 Radiant Panel Heating

Radiant heating is not normally carried out with a low-pressure hot water systems, as water temperatures required to achieve the necessary heat output tend to be high. Steam would normally be the preferred medium.

Connection to a district heating system can provide the level of water temperature necessary but will be limited to the maximum supply temperature. A circuit from a dedicated heat exchanger is possible but this will increase capital costs. The return water from this unit could possibly be used elsewhere in the building heating system before returning to the heat exchanger in order to obtain sufficient cooling of the water.

Converting a steam driven radiant panel heater is only possible if the DH system can provide the same temperatures as the steam. Costs may be incurred in installing new supply and return water pipes.

On the other hand, there are examples of radiant panels that have been designed for low temperature hot water operation, which function well and provide excellent return temperatures to the DH system.

9.1.7 Under Floor and Embedded Panel Heating

Embedded panel heaters are ideal for connecting to DH. The low supply and return water temperatures are easily achieved and provide excellent conditions for a DH system.

Little or no conversion costs are involved.

9.1.8 Electric Heating Systems

Electric heating systems such as panel heaters, underfloor systems and heat pumps cannot be converted. A change to DH will demand a new complete installation of piping and heating units in the building. The benefits in converting from electric heating systems to DH come in the reduced operating and maintenance costs, reduced use of primary fuels and increased comfort levels.

In Scandinavia and the UK, there are a number of examples of electrically heated houses being converted to hydronic heating systems and connected to DH.

9.1.9 Steam Systems

Steam systems generally are not suitable for conversion. In systems that use a 'primary' steam main and a 'secondary' hot water distribution system (typically seen in hospitals and university campuses), conversion is possible.

The 'primary' steam main can be replaced with a hot water distribution system operating at a temperature slightly higher than the 'secondary' system. The existing steam to water heat exchangers would need to be replaced, but the 'secondary' system can be left intact with no need for modification.

In many cases, such as in hospitals for example, a steam system not only supplies heating but also provides steam for autoclaves etc. This is seen as a barrier for the connection to a hot water heating system. It ought to be considered, however, as an option to provide local steam supply for the special demands and convert the steam heating to hot water, as much money can be saved in operation, maintenance and fuel costs.

9.1.10 Localized Gas-fired Heaters

These systems are also not suitable for conversion. Replacement with a new installation of piping and heating units would be required and might prove to be feasible from case to case.

9.1.11 Domestic Hot Water Heating Systems

These are ideal for conversion to DH systems. The simplicity of their design, often a single circuit heating both radiators and a domestic hot water (DHW) tank, means no modifications are necessary.

Thought may be given to removing the hot water tank in favour of a heat exchanger. The heat exchanger provides the occupants with a more flexible method of generating hot water and in dwellings with a number of occupants, provides limitless quantities of hot water and takes very little space as compared to a hot water tank. Also, a heat exchanger secures low return water temperatures.

The drawback of a heat exchanger is its relatively high heat load when in operation. In most cases, the load for hot water is much higher than for heating but only for short periods. In cases where several users are connected, the instantaneous load factor will reduce this problem. The energy loss, however, from this type of heat exchanger is much less than that from hot water tanks and the risk of problems in relation to bacteria developments is much smaller as in DHW tanks storing large amounts of water around 60°C.

It should also be noted that in areas of countries with poor water quality, hot water tanks might be preferable to plate heat exchangers as they are less prone to fouling.

Furthermore, in a number of cases, mainly in Eastern Europe and Russia, hot water supply is arranged in separate distribution systems.

10 FUNDAMENTALS OF DISTRICT HEATING

DH is where a number of buildings or dwellings are heated from a central source. Water is distributed through a double pipe network and is then transferred to buildings for use in space heating, hot water generation, process heating and even space cooling.

Often, DH systems cover large areas and are very complex plants involving many stations and thousands of consumers. A system may include more than one combined heat and power (CHP) plant, generating electricity and heat at a greater efficiency than separate plants could. In addition, a number of heat only producing plants, covering peak load and stand-by, are connected.

A DH system has three main elements: the heat sources, the distribution system and the customer interfaces. In large systems, the distribution system may be separated in a transmission system, transporting large amounts of heat energy over long distances, and a dedicated distribution system serving each building connected to the system. A transmission system may serve an entire region and cover several distribution systems in different towns.

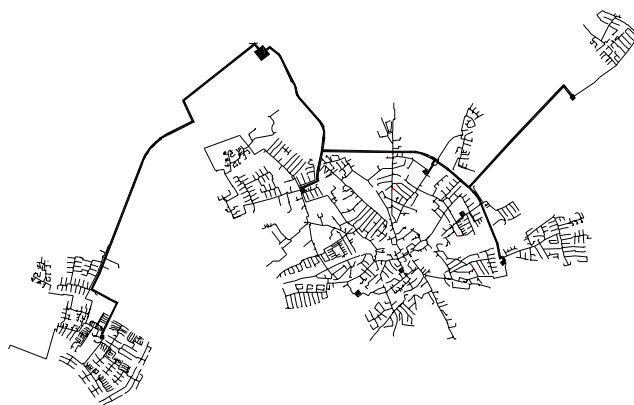

Part II Figure 10.1: Network configuration with main heat source, transmission network, boiler plants/sub-stations and distribution network

Heat Sources

There are a number of different energy sources that can be used for DH, including industrial waste heat, geothermal, solar systems and heat pumps, in addition to conventional boilers and co-generation. A low DH return water temperature enables the efficient use of low-grade energy sources. This is because low temperature return water is able to absorb more thermal energy from these sources. For this reason, the temperature level of consumer installations should be as low as possible. The level is mostly dependent on specific rules and principles, which varies from country to country. The level of return temperatures from consumer installations may vary as much as from 80 to 30°C. The use of high return temperatures often precludes many of the low grade sources of heat available.

As well, where co-generation is used, the temperature level is of utmost importance. The efficiency of any thermal power plant depends on the temperature level of the cooling water. In the case of combined heat and power generation, the DH water is the cooling water of the plant and in order to keep the total efficiency of the plant as high as possible, the return water temperature of the DH system should be as low as possible.

In any DH system, a priority regime of the heat sources connected has to be defined. This is in order to secure the operation of the most efficient and most cost-effective plant (such as CHP plants) and fuels (such as waste being treated in incinerators) during base-load periods. More expensive sources such as heat only boilers, based on oil or gas, are used for short-term peak loads only. Such plants are normally available as stand-by capacity.

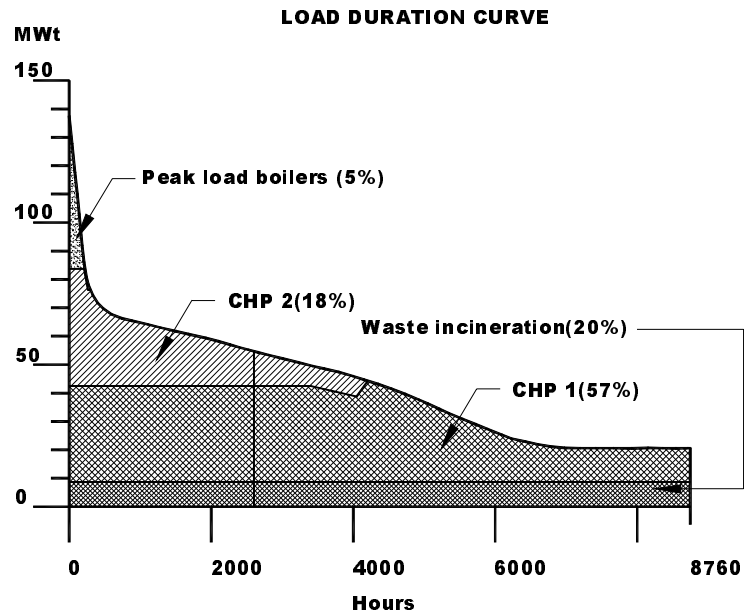

Part II Figure 10.2: Example of a load duration curve indicating the proportion of different heat sources

Heat sources can be either directly connected to the distribution system or indirectly connected through a heat exchanger.

The direct system is limited to use where water is the distribution medium and where the water quality and pressure requirements are the same for the heat source and the building's internal distribution system.

Indirect connection allows the heat source and distribution system to be operated as separate systems with different temperatures and pressures, allowing more design flexibility for both systems. Heat sources will operate at higher temperatures to avoid excessive heat exchange equipment size, thereby reducing space requirements and capital cost.

The direct and indirect method of heat source connection should not be confused with the method involved in connecting the customers heating system to the DH system. This is covered in Section 11.4.

Distribution System

DH water is distributed from the heat source through supply pipes to the customer's interface and is returned after heat has been extracted. Delivery is accomplished by circulating pumps that create a pressure differential between the supply and return pipes.

Pumps are selected to overcome the flow resistance in the supply and return pipes and also the pressure differential in the customer installation that is hydraulically the furthest from the delivery point. The use of variable speed drives to control the pumps ensures that consumed power is minimized.

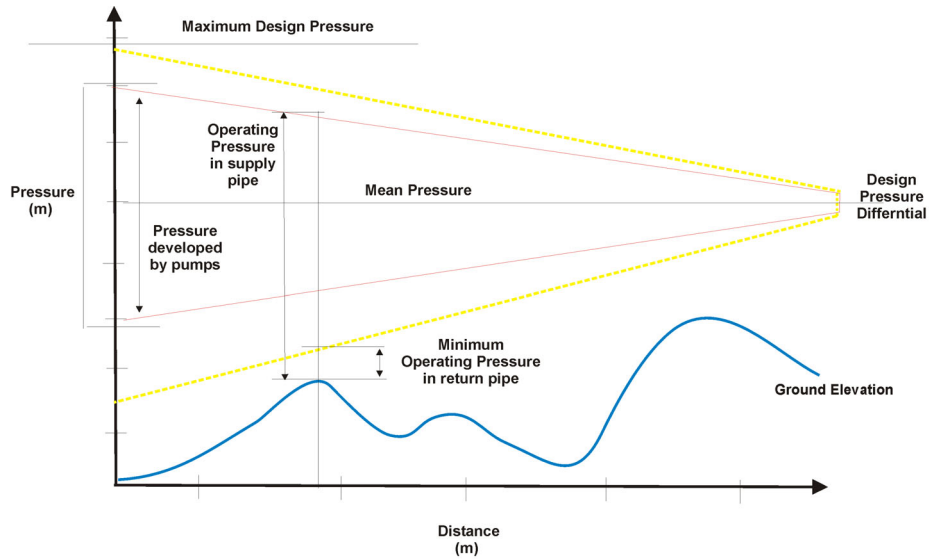

Part II Figure 10.3: DH network pressure diagram

Direct DH systems operate with supply and return temperatures in the range of $t_p/t_r=85/65^\circ\text{C}$ to $68/34^\circ\text{C}$, while indirect systems typically operate at somewhat higher temperatures; in some cases even up to $140/75^\circ\text{C}$. The greater the temperature difference between the supply and return, the lower the flow rate required. Figure 10.4 illustrates the comparative difference in pipe sizes when operating with alternative temperature differences. The DH operator will seek to ensure that the secondary return water temperature is as low as possible to minimize pumping.

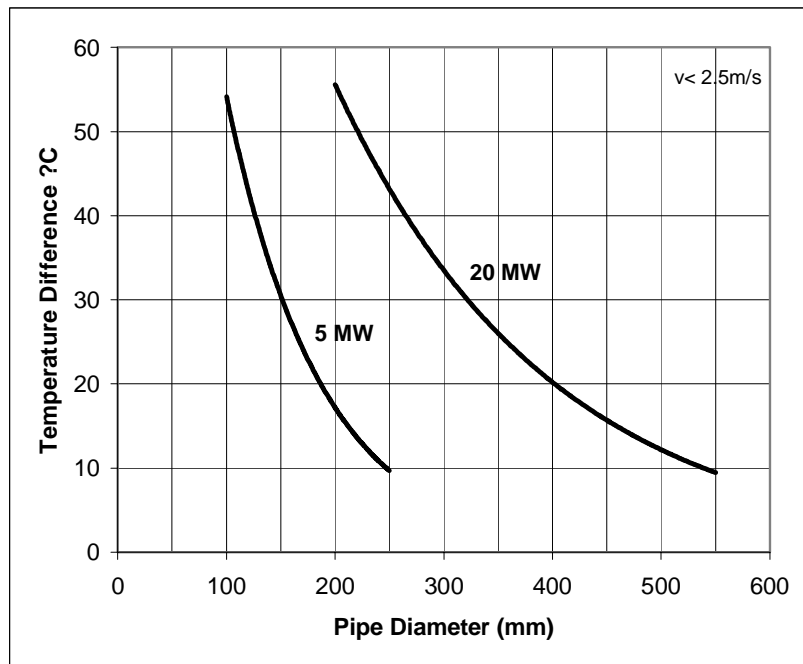

Part II Figure 10.4: Comparative pipe diameters in relation to temperature difference

It is common to compensate the DH water supply temperature. By reducing the water temperature when the heating demand decreases, energy losses from the pipe system are reduced and energy efficiency using low-grade heat sources can be increased.

Figure 10.5 is an example of how the supply temperature is controlled, depending on the outdoor temperature.

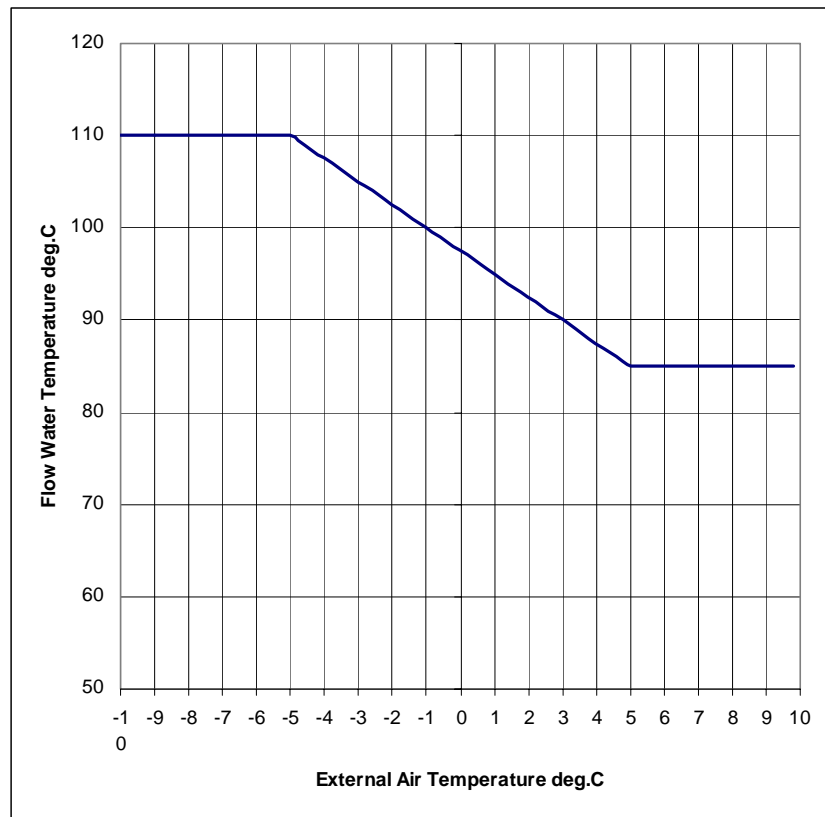

Part II Figure 10.5: DH compensation curve

Apart from this regulation over the seasons, many DH operators also aim at a general reduction of the temperature level. This is often possible due to an ongoing improvement of the building standard (improved insulation, double glazing, better control, individual metering etc.) and contributes to a general reduction of energy consumption and corresponding reduction of air pollution.

Heat losses in modern DH distribution depend on a number of factors such as the length of the system in relation to the heat load, standard of insulation and temperature level. Normally, heat losses fall in the range of 5-20% annually.

It is common to operate the supply water temperature below 120°C. Studies have shown that by reducing the normal operating temperature and by reducing the effects of pressure fluctuations, the life of the pipe work can increase dramatically.

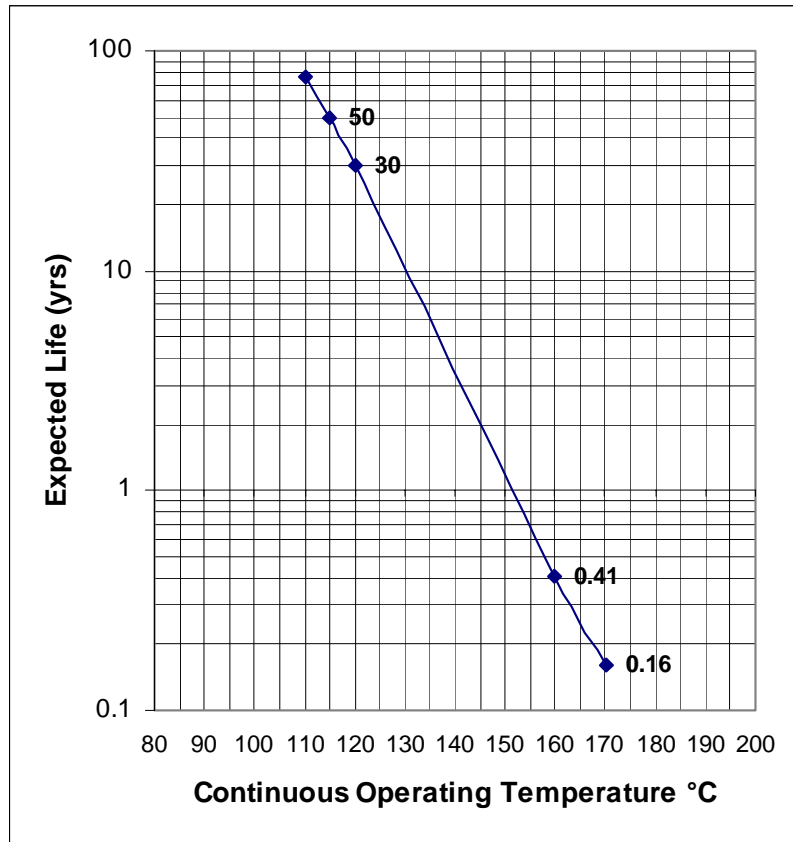

Part II Figure 10.6: Relationship between expected life of pipe and continuous operating temperature

There are a number of different types of pipe material available on the market. The vast majority of systems are based on pre-insulated steel pipes. In smaller dimensions, the media pipe may be made of stiff or flexible plastic pipes. The older types of pipework are typically made up of some kind of a concrete duct in which insulated pipes are installed manually. The reliability of these pipe systems is lower than for pre-insulated types. In general, these types of pipe systems are currently being replaced by new ones during renovation of the systems.

The DH supply water temperature is often limited by the type of pipework used. Most systems use pipework that have a maximum operating temperature of 140°C. However, it is common to operate at lower temperature, below 120°C, and even operation below 80°C is not unusual. Pressures can go up to 25 bar but the majority operates with a maximum pressure of 16 bar, while 25 bar is common in transmission systems.

Virtually all the available types of pipework are of the bonded pre-insulated type consisting of a steel carrier pipe with polyurethane foam insulation. The pipe and insulation is 'sealed' with a high density polyethylene outer casing that forms a protective barrier to external conditions. The sizes of pipework range, typically, from DN 25 mm up to DN 1000 mm, and normally come in straight lengths of 6m, 12m and 16m, which are welded in situ. Within the pipe systems, pre-formed 45° and 90° bends, isolating valves, air vents, expansion devices and anchors are included.



Part II Figure 10.7: Diagram of Alstom pipework

There are alternatives to the straight pipe systems – some employing pipes with a corrugated structure which, by the nature of their design, have a high degree of flexibility allowing them to be coiled and to be installed in curved positions. This in turn allows them, in some cases, to be installed in lengths of several hundred metres without the need for a joint and so provide a rapid installation time, lower maintenance costs and lower installation costs.

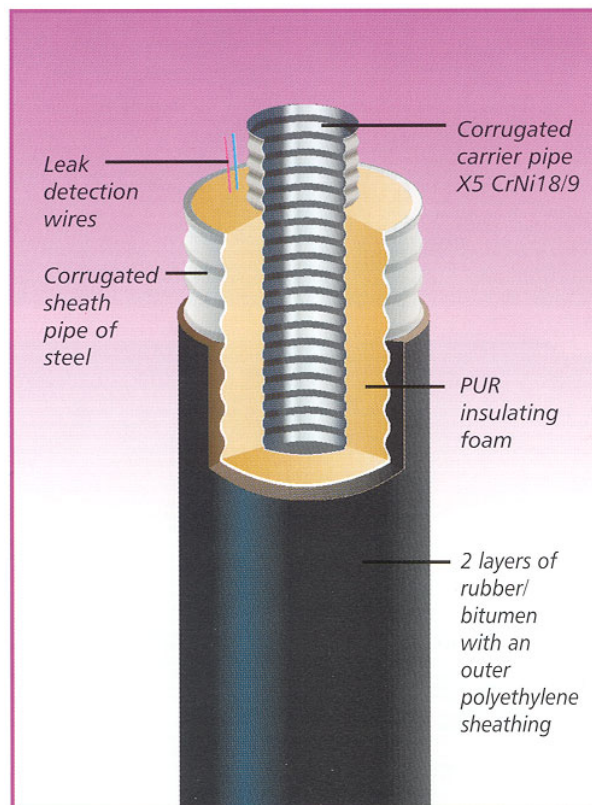

Part II Figure 10.8: Diagram of Pipe2000 Brugg Pipework

Another recent development is the installation of pipes without any measures to compensate for thermal expansion. This can be done in the "cold laid system", where anchors can be avoided. In

this case, the variations of stress in the pipe system are calculated and kept under allowable values. All direction changes have to be carried out as 90° bends or with curved pipes. Pipes in large dimensions are bent from the factory, while the smaller ones are bent on site. This concept entails considerable savings in investment.

Many pipe systems also include (within the foam insulation) a detection system that constantly monitors for the presence of moisture. Signal wires within the foam will relay a signal to a monitoring unit that will indicate the position of a possible ingress or egress of moisture to within a metre. The monitoring system provides an early warning to the DH operator so that he is able to carry out preventative corrections. Unchecked pipework can quickly deteriorate requiring emergency action and the potential loss of heat to customers.

Smaller systems use plastic pipes. These have lower operating conditions (<90°C and 6 bar) and, hence, less operational flexibility. As the temperatures are lower, plastic pipes are often used in systems that connect directly with the customers heating system (see Section 11.4.1).

The pipe systems used in smaller systems differ very little from the pipes used in larger systems but they tend to use materials other than steel. In particular, this is the case with branch pipes. Plastic carrier pipes are quite common in direct systems as operating temperatures are below the threshold of the limiting fluid content temperature. Copper and aluminium are also used – mainly for their non-corrosive properties and as such, these systems tend not to have the moisture detection system. These pipe systems are generally of smaller diameter with the largest being approximately 90 mm. Therefore, it allows them to be coiled and installed in greater lengths than straight pipe systems.

Basically, DH systems may be controlled by two different principles. Either the temperature is kept constant while the flow is varied in order to respond to the changing demand, or the flow is fixed and the temperature varies. In reality, different combinations of the two systems are found. Generally, the variation of flow responds much quicker to changes of demand than changes of temperature do. Therefore, variable speed pumps are important elements of modern DH systems.

Control of a DH system is normally undertaken by a centralized control and monitoring system (CCM). Continuous monitoring of key temperature and pressure elements in the system ensures that the system responds to the demand from the customers. In selected points of the network, pressure and temperature transmitters are installed in order to provide the decisive in-data for the control centre. Also, it is not uncommon to install such transmitters within customers plant rooms (especially those who are at the outermost reaches of the DH system) that are also relayed back to the CCM centre for use in accurate delivery conditions.

Customer Interface

Building systems may be connected directly or indirectly to the DH distribution system.

With a direct connection, the DH heating water is distributed within the building to directly provide heat to terminal equipment such as radiators, unit heaters, etc. Guidelines for direct connection are addressed in detail in Section 11.4.2.



Part II Figure 10.9: Directly connected installation. The main pipes are coming into the building in the foreground

An indirect connection uses a heat exchanger in the building to transfer the energy from the DH heating distribution system (primary system) to the building distribution system (secondary system). Guidelines for indirect connection are addressed in detail in Section 11.4.1.

The method of generation of domestic hot water is common to both systems in that a heat exchanger or a storage tank is used. The use of heat exchangers not only reduces costs but also minimizes space requirements and standing losses (from hot water tanks). Domestic hot water generated in heat exchangers also means that hot water can be produced instantaneously and constantly.

The use of hot water storage tanks is not common in new systems but should not be precluded. However, the designer should consider other issues such as bacteria growth in stored water.

In some cases, mainly in Central and Eastern Europe, hot domestic water is provided through a separate distribution system for this purpose only, and water is supplied directly to the taps in the buildings covered by this system. In these cases, the DH system consists of two double pipe systems.

Benefits to the User

Compared to owning and operating an on-site boiler, conversion to DH can benefit the user through increased reliability, greater comfort, reduced investment, operating cost savings, increased energy efficiency and greater fuel flexibility.

10.1.1.1 Reliability

DH systems are built with stand-by heating capacity to ensure that heat is always available at the central plant. Larger distribution systems are generally designed with multiple loops or with other back-up to provide additional reliability in distribution. In the case of equipment or pipework failure, the operator will have sufficient staff and resources to initiate an instant repair as soon as the failure has been identified. Under normal circumstances, a preliminary or a final repair will be made within 24 hours. In this way, the reliability provided by a properly designed, constructed, operated and maintained DH system is greater than most buildings can achieve on their own.

10.1.1.2 Tenant Comfort

Hot water DH provides even heating that is easily controlled, particularly when compared to older heating systems. The result is greater tenant comfort.

10.1.1.3 Reduced Investment

In a new building, the owner avoids the cost of purchasing a boiler and associated facilities such as a flue. Owners of existing buildings facing repair or replacement of the boiler can also avoid these costs. Building space, which would otherwise be required for the boiler room, can be used more productively as a heat exchanger can require as little as 10% of the floor space required by a conventional plant.

10.1.1.4 Building Operation Costs

DH is a more convenient way to heat a building because it eliminates the need to operate and maintain a conventional boiler plant. This results in savings in staff, administration, electricity and supply costs. In larger buildings, the staff savings can be significant.

If equipment for remote reading of heat meters and other measuring equipment is installed, the DH operator or other service companies will be able to monitor the conditions of buildings and in this way, possibly take over the complete responsibility of the heat supply and its operation.



Part II Figure 10.10: Heat exchanger substation located above a car park bay

10.1.1.5 Energy Efficiency

Conversion to DH can result in substantial energy savings. The user pays only for the heat that is actually used, whereas a building boiler often operates at a low efficiency. Conventional boilers, normally used for heating systems, are often quoted at having efficiency well above 80%. Cyclical firing, under part load conditions, means that realistic efficiencies are somewhat lower.

Efficiencies on a yearly basis, within a range of 45-65%, are not unusual. Domestic hot water can be generated instantaneously through a dedicated heat exchanger, saving the losses incurred with storage and eliminating the time delay in regeneration.

Modern DH systems are normally based on the use of as much heat as possible, not depending on traditional fuels like coal, oil and gas. Municipal waste and biofuels are such examples. In addition, the combined generation of heat and power substantially reduces the fuel consumption, as only very little heat goes to waste in this process in comparison to separate generation of electricity and heat.

10.1.1.6 Fuel Flexibility

Due to economies of scale, it can be cost-effective for larger DH systems to use a variety of energy sources. As a result, many DH systems can switch among heat sources depending on what is most cost-effective at a particular time. This flexibility improves the security of supply and is generally not achievable by an individual building heating system.

Additional efficiency improvements often occur as a result of modifications to the building systems, particularly when converting older systems. The replacement of the heat source often encourages replacement of pumps, insulation and key control elements.

10.1.1.7 Aesthetics and Environment

The building appearance can be improved because no flue is required. Also, the DH operator takes responsibility for the control of any air emissions. The DH connection requires no ventilation or fire protection and is silent. It can be located in places deemed to be unsuitable for a boiler plant.

Due to the flexibility of using a wide variety of generation technologies, alternative fuels and heat sources, the total fuel consumption of DH systems typically are substantially lower than by individual systems. This is to the benefit of the local city environment but also reduces global pollution and its possible effect on global warming.

11 INTERFACE DESIGN

Introduction

This chapter will focus on key elements that should be considered when designing the interface between the existing building heating system and the district heating system. Not all heating and hot water systems can be easily interfaced with DH, so this chapter will also address design principles for new systems.

Design Considerations

11.1.1 Pre-Design Survey

It is important to establish the capacity of the building's existing heating and hot water systems. A site survey will easily establish the nature of the system and may also ascertain the major plant criteria. In some circumstances, it may not be practical to undergo a full survey of the building. Therefore, some general investigative work and logical assumptions may have to be made.

Clearly, if a building has no secondary heating or hot water distribution system, i.e. it is electrically heated or has localized unit heaters, it will be necessary to adopt a completely fresh approach to the building design. The principles for connecting to a DH system will, however, still be valid and it is important that the engineer understands and includes them in his design.

In existing hydronic heating systems, the boiler load must first be established. This will generally be found on the boiler rating plate or within design, operating or maintenance records. In larger buildings, it is common to have more than one boiler installed – typically in a two boiler installation, each would be rated at least 60% of the total duty, primarily to ensure a minimum supply of heat, should one fail. Knowledge of the annual consumption of energy is important as it indicates the likely consumption of DH, since the maximum heat load can be derived. The annual heat consumption can be established from the fuel bills over the previous years; possibly taking the climate dates of unusually mild or harsh winters into consideration.

The number and types of heating circuits should next be established. Careful attention should be taken to ensure that the circuit with the greater demand for temperature is noted, as the heat exchanger will ultimately need to be designed to meet it. Circuits with lesser demands for temperature will, in normal circumstances, require compensation. As mentioned above, the actual operational temperatures of a system may not necessarily be identical with the design values. In order to achieve the maximum efficiency of the total system, it is important to obtain the best possible knowledge of the required temperatures. This data may be obtained from reading instruments during operation, from existing files or from personal experience held by present staff.

A note of all pipe sizes to each circuit will enable the heat exchanger to be optimally sized and configured. Pipe sizes will also provide the designer with an indication as to the needs of each circuit if no other information is available.

All circulating pumps will need to be surveyed to ascertain their rating. Conversion to DH would not necessarily require the replacement of circulating pumps as heat exchanger secondary side pressure drops are generally in the same order of magnitude as conventional boiler plants. Typically, one would expect conventional boiler plants and a complete heat exchanger station to both have a secondary water side pressure drop of 20–50kPa.

All this information should be collated and recorded and ideally, a sketch or schematic representation of the boiler/plant room should be produced.

Another aspect of great importance for the design of the interface is the standard of the building as such. In many cases, buildings have been renovated, extended or the use may have changed since it was originally built. Such changes may have involved the heating system directly or indirectly, for example, the installation of thermostatic radiator valves or the replacement of windows with double glazed types. Obviously, such changes will have had an influence on the energy consumption and the pattern of use, which should be covered by the interface design.

Regardless of any changes that may have taken place, it may still be beneficial to investigate further improvements of the central heating system in order to obtain valuable energy or operational savings.

Finally, consideration should be given to any planned modifications, as they may have an impact on the interface design and possibly to the size of the branch connection. In extreme cases, it may even impact the layout of the network.

11.1.2 Secondary Design Temperatures

The design temperatures for the heating heat exchanger will be based upon the peak winter condition. Ideally, the DH operator would like to receive the return DH water at the lowest temperature possible. Realistically, however, the building connected will determine the secondary approach temperatures and so the design will be slightly different.

As an example, in a given system with a supply temperature of 105°C, the table below illustrates the difference between theory and reality. The ideal conditions are what should be strived for in order to reduce operating costs for the customer and energy use of the DH operator. Effort in optimizing the plant can improve the operating temperatures.

Part II Table 11.1: Comparative design temperatures

	Probable	Realistic	Ideal
DH supply temperature	105°C	105°C	105°C
DH return temperature	73°C	67°C	42°C
Secondary supply temperature	82°C	85°C	70°C
Secondary return temperature	71°C	65°C	40°C

As mentioned in Section 9.2.2., temperature conditions vary from country to country and must be acknowledged. However, whether the design values are high or low, it will also be beneficial to look for possibilities to reduce operating temperatures wherever possible. Obviously, a plant must not operate at high temperatures if it can provide the necessary amount of heat at lower values – especially during the mild seasons when it may be possible to reduce temperatures.

According to experience in the operation of DH systems, it is particularly worthwhile to strive for low return temperatures in order to obtain the lowest overall costs.

In buildings to be converted to DH, which have an existing heating system that demands a certain supply temperature, a number of options exist to ensure the DH return water temperature is lowered without compromising the ability of the system to deliver the required level of heat. The table below shows the relative output of radiators if the inlet and outlet temperatures are different from the design criteria (being 82/71°C in this case). The numbers indicate the output in comparison to 100 for the design criteria.

Increasing the supply and decreasing the secondary return water temperatures will achieve this. The effect on output can be calculated as shown:

If the mean surface temperature at 82/71°C, $t_m = 76.5^\circ\text{C}$. At supply and return temperatures of 85/65°C, $t_m = 75^\circ\text{C}$.

The output of the heat emitter is a function related to its emissivity, expressed by the index n . For radiators the value is 1.3. Therefore, the output q_o from a radiator, with modified supply and return temperatures, can be expressed as a percentage of the output q at the original design temperatures:

$$q_o = \left(\frac{75.0}{76.5} \right)^{1.3} \times 100 \% = 97.5\%$$

Other heat emitters, such as natural and forced convectors (including heating coils in air handling units), have emissivity indices of 1.4 and 1.0 respectively. All of which can be tabulated to show the effect of changing supply and return temperatures.

Part II Table 11.2: Effect of modified secondary temperatures on emitter outputs

	85/70	85/65	85/60	85/55	80/70	80/65	80/60	80/55
Radiators	101.7	97.5	93.3	89.1	97.5	93.3	89.1	85
Natural Convection	101.8	97.3	92.8	88.3	97.3	92.8	88.3	83.9
Forced Convection	101.3	98	94.8	91.5	98	94.8	91.5	88.2

All indicated values are a percentage of the output at 82/71°C.

The table shows that return water temperatures can be dramatically reduced with only a marginal effect on the output of the emitter. Quite often, boiler plant, pipework and radiators are oversized and therefore the modified conditions can be applied without any loss of performance by the heating system.

Controlling the supply temperature as a function of the return temperature can be achieved by inhibiting the primary control valve opening. If the return water temperature begins to rise, it is because less heat is required to be emitted to the space for a given fixed emitter output and supply rate. By installing a temperature sensor in the return pipe, the control valve can be inhibited if the temperature rises above a set point. Care must be taken to ensure that process requirements are maintained and the two can be achieved by installing control valves on individual heating circuits.

As mentioned in Table 9.1, the design temperatures for radiators in Denmark today are 70/40°C. Until recently, they operated at 90/70°C, as in many other countries. Despite this, the great majority of district heating plants were designed for 80/40°C and were actually operating with these temperatures. The consumer installations generally were (and still are) directly connected. Obviously, the return temperature was different from house to house, depending on the size of the radiator installation, but return temperatures down to below 30°C were not unusual.

11.1.3 Domestic Hot Water - Design Temperatures

As domestic hot water has a year round demand, the heat exchanger must be sized to ensure that hot water can be generated, even when the DH temperature is its lowest, i.e. in summer months.

The temperature of municipal cold water varies from country to country and time of year. In warmer months, the DH operator may reduce the supply water temperature to a level still sufficient to generate hot water, for example 85°C. The heat exchanger will therefore need to be designed at the planned summer temperature of the DH system. If it is assumed that the municipal cold water is at a temperature of 8-11°C, the approach temperatures in this example will be;

Part II Table 11.3: Domestic hot water design temperatures

DH supply temperature	85°C
DH return temperature	25°C
Hot water supply temperature	55-65°C
Cold water temperature	10°C



Part II Figure 11.1: Heat exchanger for hot water supply in an office building connected directly to the DH system

Heat Exchanger Substation Design

11.1.4 General

A substation may be installed in each building being served by DH. In some cases, groups of buildings are also served by one substation.

Basically, the substation is comprised by isolation valves, a heat exchanger or tank for the preparation of domestic hot water, strainers, controls, pipework, insulation and a heat meter. Also, indirect systems, a heat exchanger, circulating pumps and a pressurization unit will be provided.

It is important that substations are designed, equipped, operated, and maintained according to common rules, which are to be set by the DH operator in order to secure energy efficient operation. DH operators normally install the branch connections, including isolating valves, just inside the building wall. The consumer will engage local plumbers to install and maintain the substation, according to general rules set out by the DH-company. In some cases, the operator will even design, procure, and install the substation on behalf of the customer.

11.1.5 Heat Exchanger

The heat exchanger provides the interface between the primary and secondary systems and ensures hydraulic separation is maintained at all times.

There are several types of heat exchangers designed specifically for use with DH systems.

Plate heat exchangers generally have a cost advantage and require less space compared with most standard shell and tube exchangers. They require significantly less surface area, for the same operating conditions, than shell and tube units because they have much higher heat transfer rates. With plate exchangers, the approach temperature between the primary return and the secondary return is closer, generally 1-2°C, compared with 6-7°C for most shell and tube exchangers. For this reason, DH operators often favour the plate type.



Part II Figure 11.2: A complete heat exchanger substation

Plate heat exchanger design has two options;

- brazed plate
- gasket

Brazed plate heat exchangers are sealed units that cannot be disassembled and, hence, cleaned like a gasketed plate heat exchanger. They tend to be smaller than gasketed heat exchangers as more surface area is devoted to heat exchange. They also do not require the level of maintenance required by the gasketed option. Care does need to be taken, however, to avoid fouling. This can be achieved by the use of strainers (always recommended) and occasional flushing. Generally though, the DH heating water must be treated to a high level of purity to ensure longevity of the pipework. Therefore, flushing heat exchangers are rarely necessary. Brazed plate heat exchangers, by their very nature, cannot be internally inspected.



Part II Figure 11.3: Brazed plate heat exchangers

The gasket option tends to be more expensive and the cost of a full service – required every five years or so - may outweigh the cost of a brazed plate unit itself. The gasket material often degrades losing its flexibility and hence its ability to seal. The result of this is water leaks. Gasketed heat exchangers especially tend to suffer in systems where the heating is frequently switched on and off.

An exception when gasketed heat exchangers are preferable to brazed plate units is when used within a swimming pool system. Heavily chlorinated water attacks and breaks down the brazing so a gasket type should be used. For safety, it may be advantageous to have an intermediate heat exchanger, although this design will mean the return water temperatures will be higher than desired.

Shell and tube heat exchangers are still being used in some DH systems but are gradually being phased out, as they do not provide sufficiently low approach temperatures between primary and secondary side water. They also take up a lot of space.

Shell and spiral tube heat exchangers do not share the disadvantages of other types of shell and tube heat exchangers, and are excellent for district heating applications. These exchangers are comparable to plate exchangers with low fouling resistance and high turbulence for high heat transfer. This type of heat exchanger has no gaskets, so they require less maintenance than gasketed units.

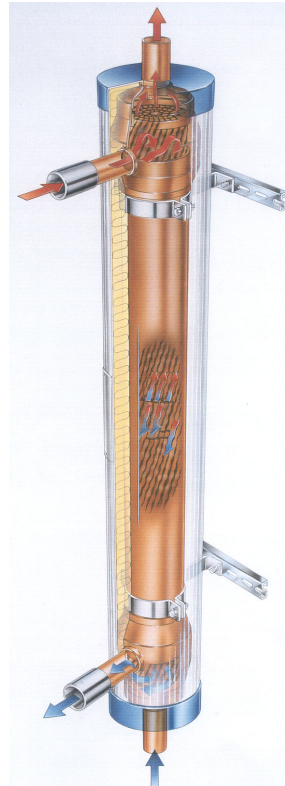

Part II Figure 11.4: Typical shell and spiral tube heat exchanger

The size and number of heat exchangers to suit the building load should be carefully selected. Using two or more exchangers, in parallel, is only needed when security of supply is critical or the customer has strong views. In this instance, total redundancy should be assumed and each heat exchanger should be capable of full load operation and full isolation without affecting the other. Normally, however, one heat exchanger is sufficient to satisfy the building needs.

11.1.6 Heat Exchanger Specification

Heat exchangers should ultimately be sized in accordance with the temperatures at peak demand and should be sized, in all instances, to effect as low a DH return water temperature as possible in all conditions. This can be easily achieved if a more relaxed view of the secondary water temperatures is taken.

The heat exchanger should in all instances be designed to suit the maximum pressure rating of the DH system. In the avoidance of any doubt, the DH operator should be consulted for the primary conditions, unless strict rules in this respect is already available from the operator.

The two key factors in heat exchanger sizing are heat transfer area and pressure loss. Heat capacity is dependent on mass flow rate and the temperature profile. Clearly, a reduced temperature difference will increase the mass flow and pressure loss. As pressure losses are aimed to be kept to a minimum, this will have the effect of requiring the surface area to be increased with the subsequent increase in the number of plates and cost. Permissible pressure losses across the heat exchanger can be summarized as shown in Table 11.4.

Part II Table 11.4: Permissible pressure losses through a heat exchanger

	Primary	Secondary
DHW	<20kPa	10kPa/<50kPa*
LPHW	<20kPa	20kPa

*when fed directly from MCW

Additional equipment such as strainers and control valves also presents a pressure loss and it is advisable for these to be kept to a minimum. DH operators will seek to achieve a 50-60kPa difference between primary supply and return pipes so it is important that there is careful choice of equipment.

The choice of heat exchanger material is essential. Carbon steel should at all times be avoided, AISI 316 stainless steel being the preference. AISI 304 is an acceptable alternative in many cases.

Heat exchangers should always contain a rating plate fixed to the end plate and, as they should be supplied with an insulative casing, one visible on the outside. The following data should be included;

- manufacturer
- type
- serial number
- maximum output (kW)
- primary and secondary design temperatures (°C)
- primary and secondary operating pressures (MPa)
- primary and secondary test pressures (MPa)
- primary and secondary side pressure drop (kPa)
- primary and secondary flow rates (dm³s⁻¹)
- primary and secondary water volumes (dm³)

The end plate shall clearly indicate the function of each pipe connection – incorrect installation can have serious consequences.

11.1.7 Controls

The secondary side of the hot water district heating systems is often designed so that the forward temperature varies according to the outdoor temperature. This control method reduces energy costs and helps to optimize conditions for the control valves because a certain minimum flow is maintained. A temperature transmitter in the secondary supply pipe measures the process value and this value is held up against a specified set point condition in the control system.

A control valve, located in the primary heating mains, achieves control of the secondary water temperature. Generally, only one control valve is installed, but if the required valve size is large, it is advisable to use two valves - a winter and a summer valve - connected in parallel and operating in sequence. For best control, in most cases, the two valves should be sized to handle one-third and two-thirds of the total capacity, the smaller being the lead valve. When redundancy requirements are high or equal loads are required for all heat exchangers, it is advisable to install separate control equipment for each heat exchanger.

Two-port control valves are used rather than three-port because in general, it is most economical to circulate the water in the heat exchanger only once.

Control valves can be either electrically driven or self-acting with no external power supply. All control valves should be capable of being manually overridden, providing the operator with the option of controlling the flow.

Control valves on domestic hot water heat exchangers must be designed to close upon a power failure. In cases where too high a water temperature is critical, a non-resetting valve should be placed in the common 'secondary' flow operating on loss of power as well as over temperature.

Temperature sensors should be located close to the exchangers being controlled in order to get a fast reacting control system.

It is imperative that the heat exchanger control valves be selected to match the building loads as oversizing will reduce valve life and cause valve hunting. Control valves should be selected with high rangeability, low leakage, and proportional plus integrating control for close adjustment, balancing, temperature accuracy and response time. Control valves should have enough power to open and close under the maximum differential pressure in the system, and should be selected to perform well with the characteristic of the heat exchanger.

Control valves are normally installed in the primary return because the lower temperature in the line reduces the risk of cavitation and increases valve life. Control valves are for temperature control only, and are not intended to be used as pressure reducing valves.

Where high or very variable differential pressures can be expected, it is advisable to install a pressure regulator in order to obtain constant differential pressure. This will improve the conditions of the control system.

Primary control valves are the most important single element in the interface with the DH system. Proper valve adjustment and calibration will save energy. High quality control valves should be selected for more precise control, longer service life and minimum maintenance.

11.1.8 Ancillary Equipment

Pressure gauges, thermometers and shut-off valves should be installed to enable proper monitoring, balancing and equipment isolation for maintenance. A balancing valve should be installed if deemed appropriate by the DH operator. This would normally be installed if the pressure difference between the primary and secondary pipes is greater than 400kPa.

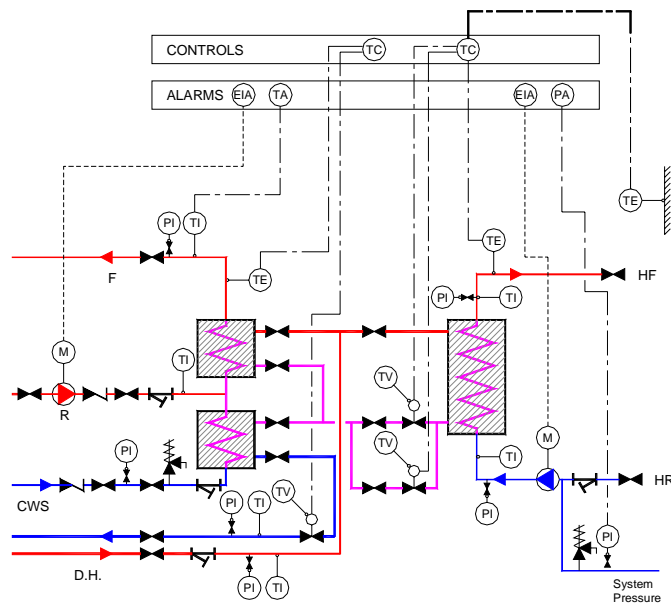

Part II Figure 11.6: Schematic of a heat exchanger substation

A strainer with a mesh of 1.0 to 1.6 mm, preferably the smaller size, should be installed. In order to determine when the strainer should be cleaned, a pressure gauge should be connected to both sides of the strainer. The pressure drop through the strainer must be considered in the system design. If necessary, a larger diameter strainer should be considered so that the flow is not restricted.

The DH operator will install draining and venting valves and these should be locked to prevent unauthorized operation. The DH operator will normally be the only key holder.

All pipework used to interconnect the heat exchanger to the primary and secondary systems should be suitable for each system.

11.1.9 Heat Exchanger Substation Location

The DH operator should be consulted regarding the location of the building heat exchanger substation because this will determine the location of the primary system piping. The room size should be readily accessible for inspection and maintenance, and its size should be suitable for disconnection and removal of equipment for repair or replacement.

As a rule, the room should be located adjacent to an external wall to avoid lengthy runs of primary pipework within the building. Clearly, this is not always possible. Therefore, isolating valves should be provided at the point of entry to the building, access to which should be maintained at all times. The valves should be lockable to avoid unauthorized operation, with the keys held by a responsible staff members of the customer organization and the DH operator. Personnel from the DH operator should be able to enter the room unassisted, but the room should be locked to keep out unauthorized personnel.

As heat exchanger substations are significantly smaller than conventional boiler plants, large amounts of space are created when boilers are removed. This can be a significant benefit to the building owner.

Connection Methods

11.1.10 Indirect Connection Method

The indirect connection method is normally used in large systems whose temperatures and pressures are not suitable for the direct connection method. This involves temperatures typically above 90°C and pressures above 6 bar. Connecting to a high pressure DH system should not be carried out unless specific heating appliances of large enough capacity warrant such treatment. In this situation, the equipment must be designed to the same standards as a heat exchanger.

The indirect method ensures hydraulic separation between the DH water system (primary) and the central heating system (secondary) of the building, allowing the DH operator freedom to manage the DH system conditions without unduly disturbing the connected customers. The indirect method employs one or more heat exchangers to interface the building heating systems with the DH system.

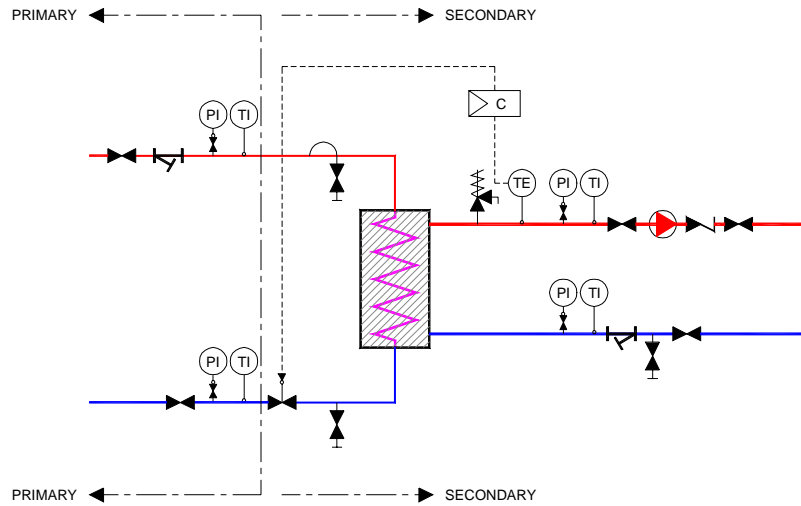

Part II Figure 11.7: Schematic representation of an indirect connection

When a building has a number of different heating requirements, the use of separate heat exchangers may be warranted. Typical examples of this are air conditioning, perimeter heating, and special requirements such as hospital theatre rooms. The use of individual heat exchangers offers a greater degree of flexibility, especially when maintenance is required.

The generation of hot water is always carried out using a separate heat exchanger. Systems with a large hot water demand would normally benefit from the use of a heat exchanger arrangement that uses the DH return water to pre-heat the cold water make-up. This is achieved through a separate heat exchanger after which the DHW mixes with the re-circulated hot water and is then heated through an after-heater to be raised to the required temperature. The result is that the DH return water temperature is lowered further. This arrangement is illustrated in Figure 11.8.

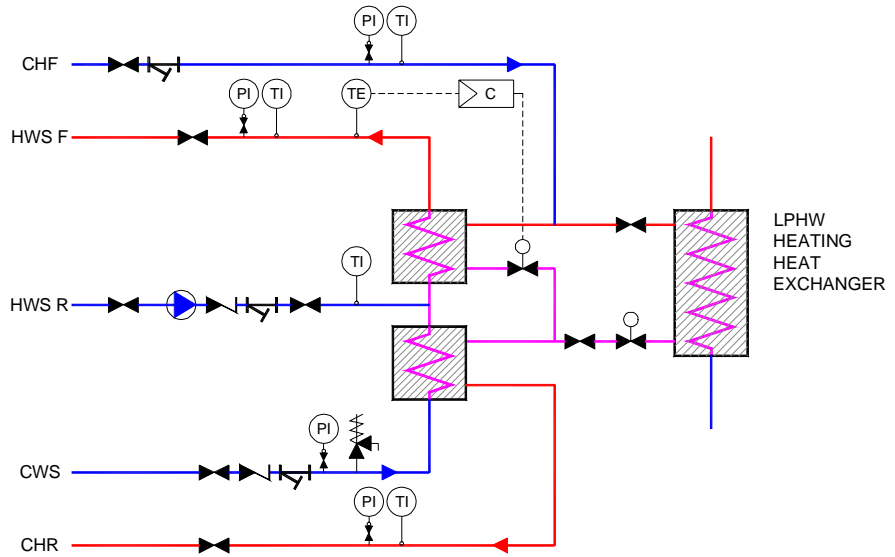

Part II Figure 11.8: Schematic representation of DHW pre-heating

Generally, the design of the secondary heating system differs little from a conventional heating system. Notwithstanding the secondary design temperatures, there are a few design features that should be considered when connecting to a DH system.

Shunt pump

The shunt pump is a common inclusion in heating systems but should **not** be used on a district heating system. The shunt pump will only serve to return near supply temperature water back to the heat exchanger. This would mean that the heat exchanger would have to be sized accordingly, making the unit unnecessarily large.

Common Low Loss Header

The common low loss header, like the shunt pump, encourages the mixing of supply and return water. This is unsuitable for DH systems and should be avoided.

Circuit Compensation

In buildings large enough to warrant a number of heating circuits, a greater use of compensated circuits should be encouraged.

Two-port Control Valves and Variable Speed Pumping

The use of two-port, in lieu of three-port control valves in constant temperature applications, ensures the unnecessary return of supply water temperature back to the heat exchanger. The use of variable speed pumps provides an efficient method of delivering only the energy that is needed.

Circuit Mixing

Wherever possible, water returning from one heating circuit at a high enough temperature should be used in a second circuit. This is not always possible since one circuit may demand energy at a different time to another. Typical examples of such circuit mixing include perimeter heating and underfloor heating. Figure 11.9 illustrates schematically how this could be achieved.

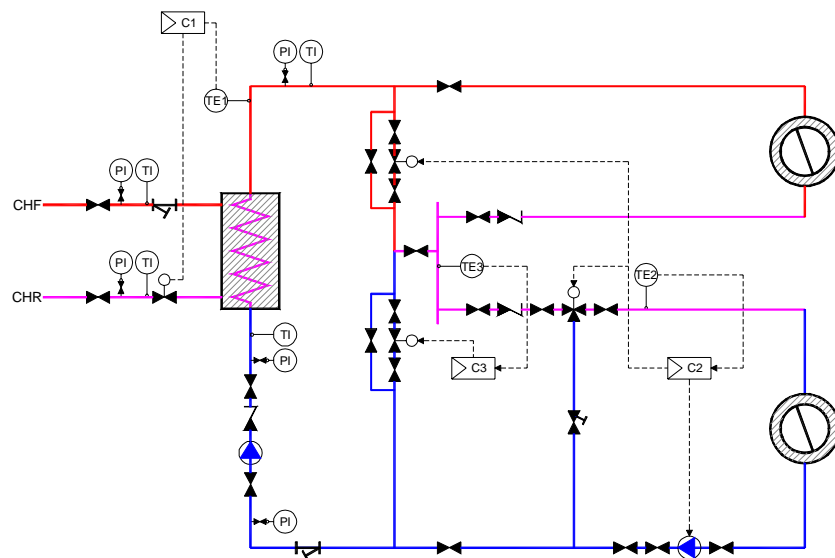

Part II Figure 11.9: Schematic representation circuit mixing

Domestic dwellings can be connected to an indirect system as with any other building. In cases where temperature and pressure requirements prohibit the use of the lower grade pipework, there is no alternative.

Small packaged units are available pre-assembled (or may be tailor-made), allowing the building owner to easily connect to a DH system. It is advisable that an approved contractor, known to the DH operator, is used. The units contain all the necessary controls (and metering if required), pumps, pressurization and hot water generation.

They differ little from the larger units but they are more likely to come in a range of sizes as opposed to larger units that are assembled specifically to meet the duty of the building.

11.1.11 Direct Connection Method

The direct connection method is normally used in systems where temperatures are below 90°C and pressures below 6 bar. Direct systems tend to be associated with systems that are predominantly made up of domestic dwellings. Larger buildings or groups of buildings with heating systems that have high volumes of water and possibly a small distribution network tend to be connected to indirect systems as the DH operator would have to distribute and treat large quantities of water.

Direct connection of the customer's terminal heating equipment (such as heating coils, radiators, unit heaters, etc.) to the primary distribution system is in some cases more economical than the indirect method. No heat exchangers, pumps or water treatment systems are required in the customer installation, thereby reducing the investment costs. There is also the potential for obtaining a somewhat lower DH return water temperature. Direct connection should especially be considered in new development areas where building heating systems could be designed for direct connection.

When designing a direct system, care must be taken to protect the safety of the customer installation and the reliability of the DH system. Direct connection increases the opportunities for damage, contamination and leakage, which could affect the entire system. Equipment within the property should ideally be tamper resistant.

The pressure differential in the distribution system changes with the load and with distance from the heat source, and is sometimes larger than desired within building systems. To minimize noise and control problems, a constant pressure differential control valve should be installed in the buildings.

Normally, the DH system supply temperature is the same as that required in the buildings. Figure 11.10 shows the simplest form of direct connection, which includes a pressure differential regulator, a pressure relief valve and a check valve. Special attention should be given to potential noise problems at the thermostatic valves. These thermostatic valves must be specified to correspond to the design pressure differential.

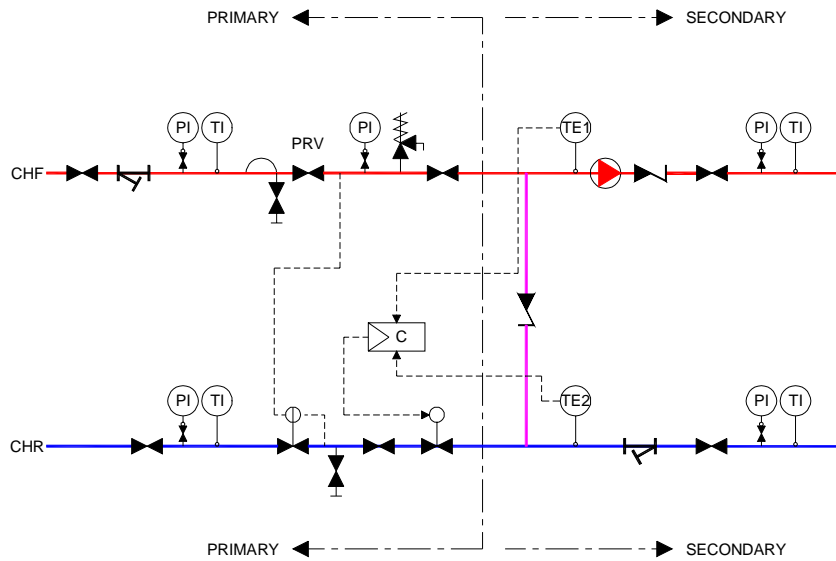

Part II Figure 11.10: Schematic representation of a direct connection

The DH operator may be able to realize benefits in distributing at higher temperatures and designing the control equipment at the customer to regulate the temperature. There is also a potential for a larger temperature differential between supply and return, which reduces the required pipe size. The desired supply temperature within the building is then achieved by compensation. Figure 11.11 illustrates this approach.

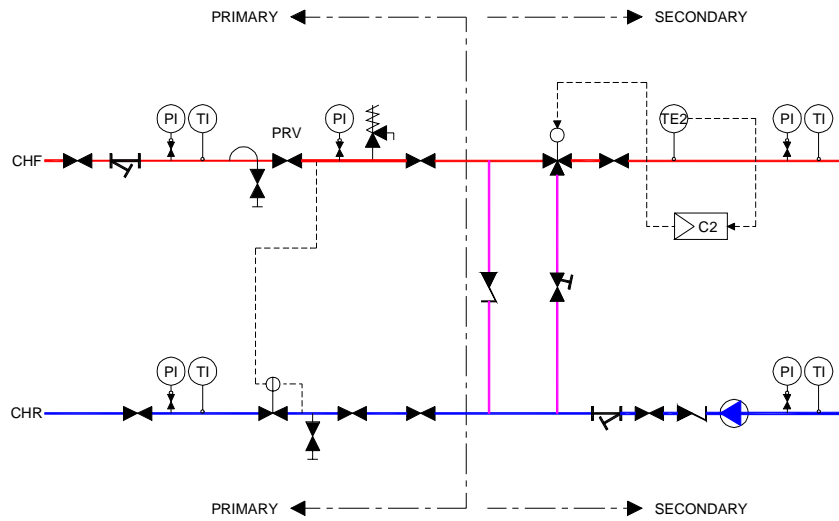

Part II Figure 11.11: Schematic representation of a compensated direct connection

Depending on the size and design of the main system, elevation differences, types of customers and building systems, additional safety equipment such as automatic shut-off valves on both supply and return lines may be required.

Domestic hot water generation can be achieved in two ways:

- conventional storage tanks, or
- secondary heat exchanger.

Most buildings with existing hot water generation will utilize storage tanks. When connecting to a DH system, it is important to ensure that the DHW tank coil is sufficiently sized to cater for any changes in supply and return water temperatures as the regeneration time may be affected. Generally, the existing system can be left in tact, reducing the need for investment. However, it will normally prove more economical in the long run to replace existing installations with systems specifically designed for DH, whereby the optimal temperature conditions can be obtained.

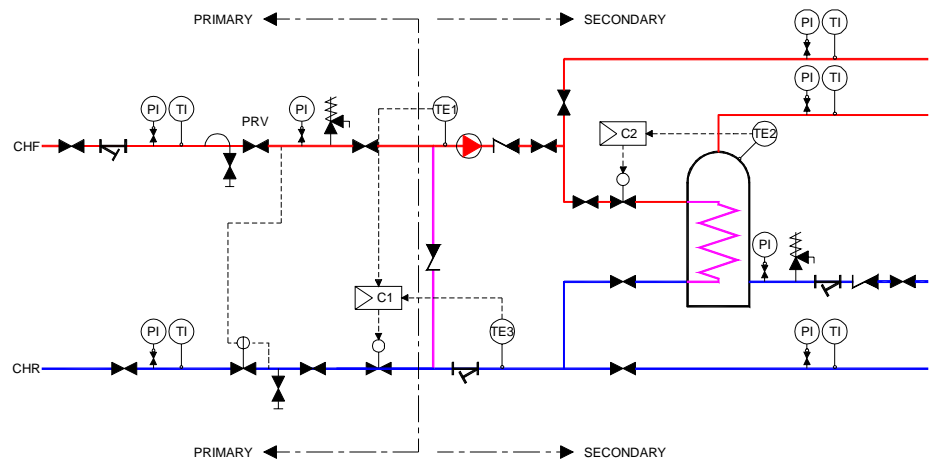

Part II Figure 11.12: Schematic representation of domestic hot water generation in a direct connection

The use of a heat exchanger to generate hot water does provide an alternative. With hot water generated through a heat exchanger, the customer is furnished with an unlimited supply of hot water as there is no regeneration time – the water is heated instantaneously.

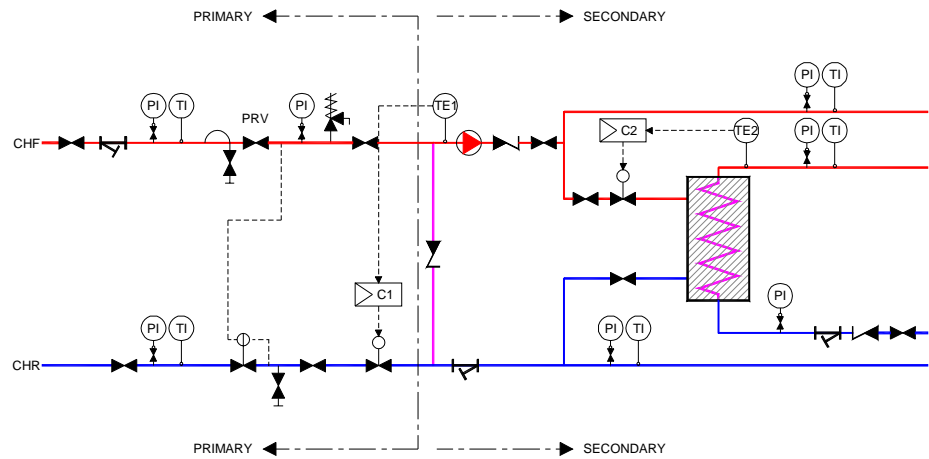

Part II Figure 11.13: Schematic representation of domestic hot water generation in a direct connection through a heat exchanger

It is common to provide a control station that interfaces with the DH system. The control station is generally made up of isolating valves, gauges, thermometers, control valves and a heat meter.

A number of manufacturers produce heating control stations specifically designed for use in domestic dwellings and can include a heat exchanger for generation of hot water.



Part II Figure 11.14: Domestic substation

Secondary Heating Systems

11.1.12 General Considerations

One heat exchanger can serve several sub-circuits and more than one type of sub-circuit. In larger buildings, however, it may be advantageous to have separate heat exchangers for different types of demand or when temperature requirements are significantly different.

11.1.13 Distribution

As two-port control is recommended, distribution should be carried out by variable speed driven circulating pumps. The benefits of variable speed pumping have been demonstrated in many systems including improved air elimination, elimination of balancing devices for pumps, sub-

circuits and each heating element due to better controllability. By variation of the flow, according to consumption, the lowest return temperature is obtained at any time.

11.1.14 Heating & Ventilating Equipment

As previously discussed, a low water return temperature is an important requirement of the DH system. Section 11.2.2 generally covered the differing approaches to ideal secondary design temperatures. Based on the same example, Table 11.5 shows the design objectives for the different types of secondary heating circuits.

Part II Table 11.5: Design temperature objectives for secondary heating circuits

	Supply	Return
Radiator circuit	85°C	60°C
Heating coils	85°C	55°C
Under floor heating	45°C	30°C
Embedded panel	55°C	35°C
Domestic hot water	55°C	10°C

Many of these temperatures are quite common in several countries. There are many situations of even lower values in, for example, radiator systems, as low as supply/return = 70/30°C. Modern air handling units are equally designed for operation with very low temperatures and will be able to operate at, for example, supply/return 35/<20°C. This means they are able to operate with return DH water as the supply to the unit.

There are other examples of systems being designed for operation on return DH water, but obviously, this is only possible in a limited number of installations in a certain network, as the downstream return temperature will gradually decrease.

Domestic Hot Water

Domestic hot water temperatures must comply with the national codes as indicated in Table 9.1. However, it is to be expected that these demands may also be lowered over time, which has already happened in some countries in order to save energy. In most cases, a DH supply temperature of 70°C will be sufficient and is therefore probably the lowest possible temperature, which will be sufficient in the summer.

11.1.15 DHW Heat Exchanger

In buildings with a relatively large hot water demand, a pre-heater can be used. In this approach (Figure 11.8), the water is pre-heated by return water from the space heating system. In addition to reducing the primary return temperature, this approach reduces lime build-up in the heat exchanger, extends equipment life and reduces maintenance costs. In the warmer months, when there is no space heating load, another heat exchanger (post-heater) using primary water can provide the load for the domestic hot water.

As the municipal cold water quality differs from country to country and from region to region, careful selection of the unit should take place. Sufficient allowance should be made for fouling and a suggested minimum is 0.0004 m²/°C.W.

11.1.16 Temperature Control

As a heat exchanger for domestic hot water is non-storage, it can be required to raise a large quantity of water to the desired temperature. This clearly needs a large input of energy and as such, more than one control valve may be required. The controlling temperature transmitter should be placed in the outlet to the heat exchanger as close to the heat exchanger as possible. The lack of storage means that transient temperatures are not absorbed. Therefore, the actuated valve and controller must be capable of adjusting accurately and rapidly.

To avoid any incidents of over-temperatures, non-resetting solenoid valves that stop the flow of hot water, should be used. These valves should be designed to also close on a power failure and, in both instances, require manual intervention to reset. This will ensure that an inspection is made of the heat exchanger in case of a fault.

12 BUILDING CONVERSION

Introduction

The majority of buildings considered for district heating are heated using conventional gas, coal or oil-fired boilers. These buildings present a relatively simple task in converting to DH. Other systems in use include electric heating, which is represented by underfloor elements, heat pumps and panel radiators and steam heating systems which are often confined to use in hospitals.

This section will concentrate on the steps required to convert existing hydronic systems to DH.

Steam systems often combine standard hydronic distribution circuits with a primary steam main, while electric systems have no infrastructure to support a conversion and require the building heating system to be completely redesigned.

Even though it will take a large and expensive effort to install a hydronic heating system in any building, this is not necessarily prohibitive. Actually, most buildings had no such systems at the beginning of the 20th century, and gradually were retrofitted with this modern commodity in order to improve the standard. Obviously, new piping and radiators can be installed, and now new small bore piping, often hidden in panels are used.

In Scandinavia, quite a few homes are switching from electrical heating to district heating nowadays, and a number of family homes are presently being fitted with new pipe systems and radiators.

Conversion Procedure

In all instances, the building conversion should follow a general procedure:

- survey and schematic design
- assessing building heating load
- assessing existing components
- conversion concept and budget cost
- system design
- installation, testing and commissioning

Domestic dwellings require a less rigorous approach as they normally have fairly simple systems – typically a boiler, one heating circuit and a hot water tank.

12.1.1.1 Survey and Schematic Design

The use of existing Operating and Maintenance information should be viewed with some caution as many buildings will have undergone some modifications and improvements since the original installation. However, they will generally provide a good overview of the system. In spite of this, and in the absence of this, a thorough survey of the building heating system should be made. Producing a schematic representation of the system will help to define the scope of work. It is particularly important to identify those plant or equipment items that do not form part of the basic system but do influence the energy needs of the building.

Typically the survey should identify:

- plantroom equipment and piping layouts;
- terminal units, such as radiators, fan coils, etc.;
- air handling units;
- domestic hot water heaters;
- chilling equipment;

- kitchen equipment;
- humidification equipment;
- sterilization equipment;
- underfloor heating or embedded panel heating; and
- radiant heating.

12.1.1.2 Assessing Building Heating Load

The building's energy requirements must be established, wherever possible, based on historical usage. The impact of conversion to DH often initiates a renewed interest in the energy demands of the building. The result being that conversion often brings about improvements in energy use and a reduction in energy consumption overall.

To size the heat exchanger and associated components correctly, the building peak load should be established. The heat exchanger should not be based on the existing boiler rating plate because it is highly likely that the boilers have been oversized to begin with, notwithstanding the energy conservation measures that often come about. Oversizing of the plant is costly and results in poor controllability.

It is important to accurately estimate the building peak load as the building owner may pay a Standing Charge based, either in part or whole, on the size of the connection (in kW). In this connection, it should be noted that the operating efficiency of boilers is subject to current debate. However, it can be said that they operate well below the declared nominal efficiency.

As mentioned above, the annual fuel consumption, together with an annual load distribution curve, may be a valuable tool to estimate the peak load. A typical load distribution curve may be available for the country or region. In the absence of accurate data, the DH operator should be able to provide a 'utilization factor', expressed in hours, that can be used to determine either the peak load or the annual consumption. This is achieved simply by multiplying the connected capacity (kW) by the number of hours to produce an annual consumption in MWh.

Another method of heat load assessment utilizes a factor based on the building floor area. This is expressed in W/m^2 and gives a simple assessment procedure. Care has to be taken using this method as different buildings have different insulation properties

12.1.1.3 Existing Components

It is important to individually assess the age and condition of each component and to check compatibility with possible changes in design conditions. This process also alerts the building owner to potential maintenance requirements.

It is prudent, at this stage, to consider the extent of the useful life of existing components. The period surrounding the conversion to DH provides an ideal opportunity to upgrade/replace ageing equipment. The DH operator may provide a facility to replace old equipment. Alternatively, a reputable mechanical contractor would be able to carry out this work.

12.1.1.4 Conversion Concept and Budget Cost

The proposed conversion concept and budget cost should be presented to the building owner. It is important at this stage to ensure that the capital cost is kept as low as possible without jeopardizing obvious possibilities to reduce consumption of energy during operation, which is one of the main benefits of a DH connection. Ideally, a financial assessment of full life cycle costs and a cost comparison with conventional plants, should be presented.

12.1.1.5 System Design

The system design should include the detailed conversion design and the selection of any additional equipment needed to satisfy occupant comfort whilst maintaining optimum efficiency.

12.1.1.6 Installation, Testing and Commissioning

The installation procedure must be carefully planned. It is highly unlikely that the building owner will be in a position to hand over the heating (and hot water) system for an extended period. It is important, therefore, to program the installation to ensure the loss of heat is minimized.

The space required by a heat exchanger is generally much smaller than that required by a conventional boiler. It is therefore recommended that the heat exchanger be put in place and connected to the DH before any other work is carried out. The DH operator can ensure that his side of the system is healthy and that valves and meters operate satisfactorily before the boiler is removed.

As much as possible, any replacement pipework, valves and instrumentation should be installed at this stage. Prefabrication of sections of pipework is also suggested as a means to reduce 'downtime'. The use of additional isolating valves can allow sections of the system to be more easily connected.

The modification of heating systems will undoubtedly mean that re-commissioning will need to be carried out and it may be prudent to install new or additional testing points to facilitate correct commissioning.

13 Related References

Part I

1. IEA District Heating – Guidelines for Converting Building Heating Systems for Hot Water District Heating, Novem, 1990.
2. Application Guide for Absorption Cooling/Refrigeration Using Recovered Heat, ASHRAE, 1995.
3. ASHRAE Handbook – Fundamentals, ASHRAE, 2001.
4. ASHRAE Handbook – Systems & Equipment, ASHRAE, 2000.
5. ASHRAE Handbook – HVAC Applications, ASHRAE, 1999.
6. ASHRAE Handbook – Refrigeration, ASHRAE, 1998.
7. CoolTools Chilled Water Plant Design Guide, Pacific Gas and Electric Company, May 2000.
8. Total Hydronic Balancing, Robert Petitjean – Tour & Andersson AB, 1994
9. Design Guide for Cool Thermal Storage – ASHRAE, 1993
10. Ice Slurry Cooling/Heat Transfer/Storage: Technology Development and Demonstration, Argonne National Laboratory, <http://www.anl.gov/LabDB/Current/Ext/H266-text.001.html>
11. A Feasibility Study of Ice Slurry Refrigeration Systems, Prof. Doug Reindl & Prof. John Mitchell sponsored by the Energy Center of Wisconsin, http://sel.me.wisc.edu/info/current_research/shearburn/shearburn_main.htm

Part II

12. Tierney and Fishman, “Real World Boiler Efficiency”, presented at the 78th Annual International District Heating and Cooling Conference, June 1987, and “Real World Boiler Efficiency Update”, presented at the 79th Annual International District Heating and Cooling Conference, June 1988.
13. The Chartered Institution of Building Services Engineers, CIBSE Guide Book B. CIBSE 1986.
14. BRECSU, Good Practice Guide 234 - Guide to Community and CHP, 1998.
15. District Heating in Buildings, Requirements and Instructions. Finnish District Heating Association, Summary of Publication K1/1992.
16. Randløv P, The District Heating Handbook - European District Heating Pipe Manufacturers Association. Rambøll, 1997.
17. European District Heating Pipe Manufacturers Association. Quality Pipes EN 253 Preinsulated Bonded Pipe Systems.
18. Refrigeration and the Environment – typical applications for air conditioning. Technical Note TN 15/92. BSRIA, 1992.
19. District Cooling Handbook. European Marketing Group District Heating and Cooling, 1997.
20. www.demlocs.net

14 Glossary

Absorption Chiller – A refrigerating machine using heat energy to generate chilled water.

Air Handling System – Equipment which provides for the distribution of tempered air.

Balancing Valve – A valve installed to adjust the distribution of water to a specific location.

Battery – A coil used for heating.

Closed Loop or Closed Cycle – A cycle in which the fluid is recycled without introduction of new fluid.

Cooling Coil – A cooling element made of pipe or tube that may or may not be finned or formed into helical or serpentine shape.

Cylinder – A vessel or tank in which water is stored.

Design Pressure – The design pressure is the maximum allowable working pressure as defined in the local jurisdiction's piping code.

DH – District Heating

DHW – Domestic Hot Water

Direct Connection – Connection of building cooling equipment (cooling coils, radiant panels, etc.) directly to the primary district cooling distribution system without first transferring the heat from a separate secondary system through a heat exchanger.

Direct Return Cooling System – A two-pipe system that returns the cooling medium from the terminal exchange to the cooling source.

DN – Nominal diameter (of pipework)

Dual Duct System – A system that produces conditioned air at two temperatures and humidity levels. The air is then supplied through two independent duct systems to the points of use where mixing occurs.

Energy Transfer Station – The energy transfer station (ETS) is an interconnection between the DHC system and the consumer's hot water and chilled water system. The ETS is an indirect connection to the customer's system in the case of hot water and chilled water. The ETS consists of isolation and control valves, controllers, measurement instruments, an energy meter, heat exchanger(s), pipe, pipe fittings, and strainers.

Fan Coil Unit – A fan and heat exchanger for cooling and/or heating, assembled within a common casing.

Heat Exchanger (HX) – Equipment designed to extract heat from one system and passing it to another system. Heat exchangers are used between the district cooling system and the customer buildings, physically separating the two fluid streams.

Hydronic – Reference to heating systems using water as the energy carrying medium.

Induction Unit – A jet action device that injects treated air to entrain recirculated air through a heat exchanger.

Radiant Panel – A heat exchanger surface, embedded in the cooling or walls, with circulating water which transfer heat by primarily radiation.

Interconnecting Pipe – The interconnecting pipes run from the main isolation valves inside the building wall to the ETS heat exchangers located in the customer's existing mechanical room.

Mains Water – See MCW.

MCW – Mains cold water, towns water or city water.

Municipal Water – See MCW.

Operating Pressure – The operating pressure is the pressure at which the system normally operates.

Plate Heat Exchanger – A heat exchanger with fixed plates separating the fluids on the primary and secondary sides.

Primary System – Chilled distribution network from the district cooling utility, including the primary chilled water supply to the heat exchangers in the customer buildings served by district cooling, and the primary chilled water return from buildings.

Recirculated Air – Air taken from a space and returned to that space, usually after being passed through a conditioning system.

Return Air – Air extracted from the conditioned space and totally or partly returned to the air conditioning system.

Rooftop Unit – Equipment mounted on the roof in which conditioned air is discharged directly in the room below or through ductwork.

Secondary System – The chilled water supply and return in the customer's building, which circulates through the heat exchanger to reject heat extracted from terminal equipment and air handlers to the primary system.

Shell and Tube Heat Exchanger – A nest of tubes or pipes, or a coil of tube or pipe, contained in a shell or container. The pipe (or pipes) carries one fluid, and the shell has an inlet and outlet for flow of another fluid.

Terminal Equipment – Equipment through which heat is extracted from the building space, for example, coils, induction units, radiant panels, etc.

Three-way Control Valve – A valve having either a single inlet and two outlets (diverting valve) or two inlets and a single outlet (mixing valve).

Two-pipe system – A piping system with a supply pipe into a heating or cooling unit and a separate return pipe going back to form a closed loop system.

Ventilation Unit – A fan coil unit for applications in which outdoor and return air mixing satisfies tempering requirements and ventilation needs.